



# FORM TIE

## FORMTIE B

### 1. Both sides exposed

| Parts              | Quantity | Inner unit dia.          |
|--------------------|----------|--------------------------|
| FORMTIE with a Nut | 2 pcs    | $W^{5/16} \cdot W^{3/8}$ |
| Inner Unit B       | 1        | $W^{5/16} \cdot W^{3/8}$ |
| Plastic Cone       | 2        | $W^{5/16} \cdot W^{3/8}$ |
| Flat Rib Washer    | 2        | Common                   |

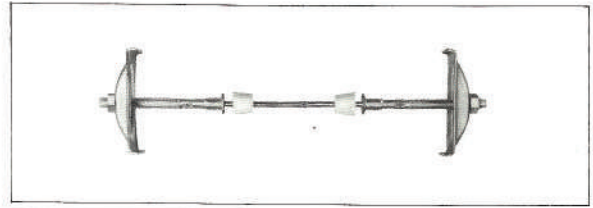

## FORMTIE C

### 1. Both sides finished

| Parts              | Quantity | Inner unit dia. |
|--------------------|----------|-----------------|
| FORMTIE with a Nut | 2 pcs    | $W^{5/16}$      |
| Inner Unit C       | 1        | $W^{5/16}$      |
| Flat Rib Washer    | 2        | Common          |

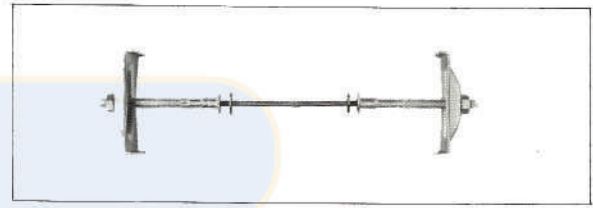

## FORMTIE BC

### 1. One side finished and other side exposed

| Parts              | Quantity | Inner unit dia. |
|--------------------|----------|-----------------|
| FORMTIE with a Nut | 2 pcs    | $W^{5/16}$      |
| Inner Unit BC      | 1        | $W^{5/16}$      |
| Plastic Cone       | 1        | $W^{5/16}$      |
| Flat Rib Washer    | 2        | Common          |

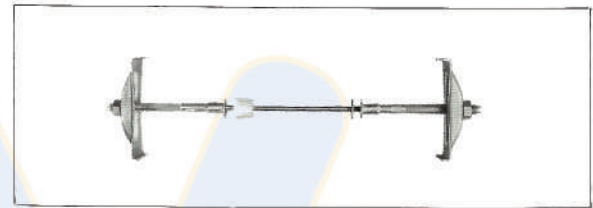

## FORMTIE D

### 1. Both sides exposed

| Parts                | Quantity | Inner unit dia. |
|----------------------|----------|-----------------|
| FORMTIE D with a Nut | 2 pcs    | $W^{1/2}$       |
| Inner Unit D         | 1        | $W^{1/2}$       |
| Plastic Cone D       | 2        | $W^{1/2}$       |
| Flat Rib Washer      | 2        | Common          |

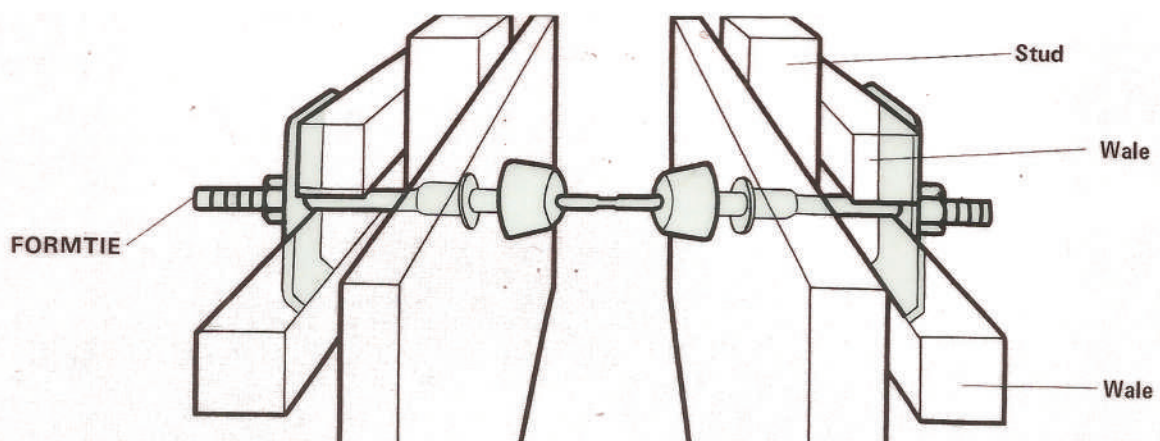
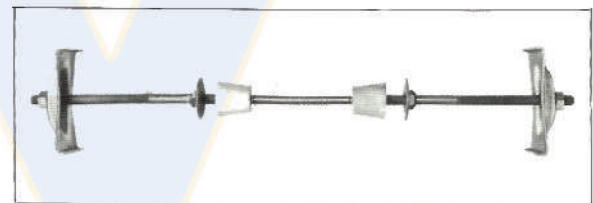

# FORM TIE

## FORM TIE



**FORM TIE B** type consists of: Form Tie C 2 pcs., Inner Unit B 1, Cone 2, Washer 2, Nut 2.



**FORM TIE D** type consists of: Form Tie D 2 pcs., Inner Unit D 1, Cone D 2, Washer 2, Nut 2.

## FOR WOOD BATTERS CLAMP FOR ROUND PIPE BATTER



Flat Rib Washer  
(200 x 55)



Flat Rib Washer  
(105 x 50)



Flat Rib Washer  
(150 x 50)



3-type  
Rib Washer D



3-type Rib Washer



KP Washer 45



KP Washer SW

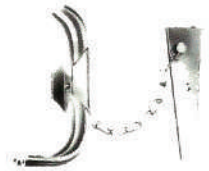

KP Washer H

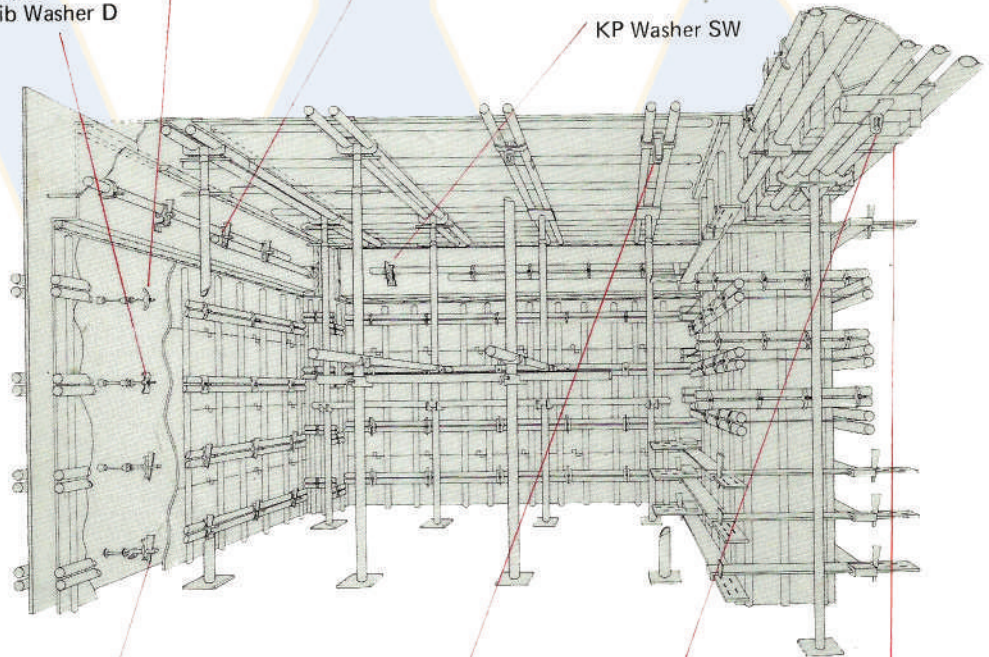

KP Washer

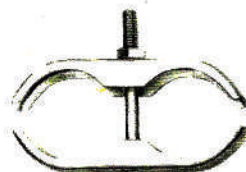

Pipe Clamp



PDCW-2



PDCW-1

Support Stabilizer



Hook Bolt

# FORM TIE



**FORM TIE BC** type consists of: Form Tie C 2 pcs., Inner Unit BC 1, Cone 1, Washer 2, Nut 2.



**FORM TIE C** type consists of: Form Tie C 2 pcs., Inner Unit C 1, Washer 2, Nut 2

## CLAMP FOR SQUARE PIPE BATTER

Support Stabilizer

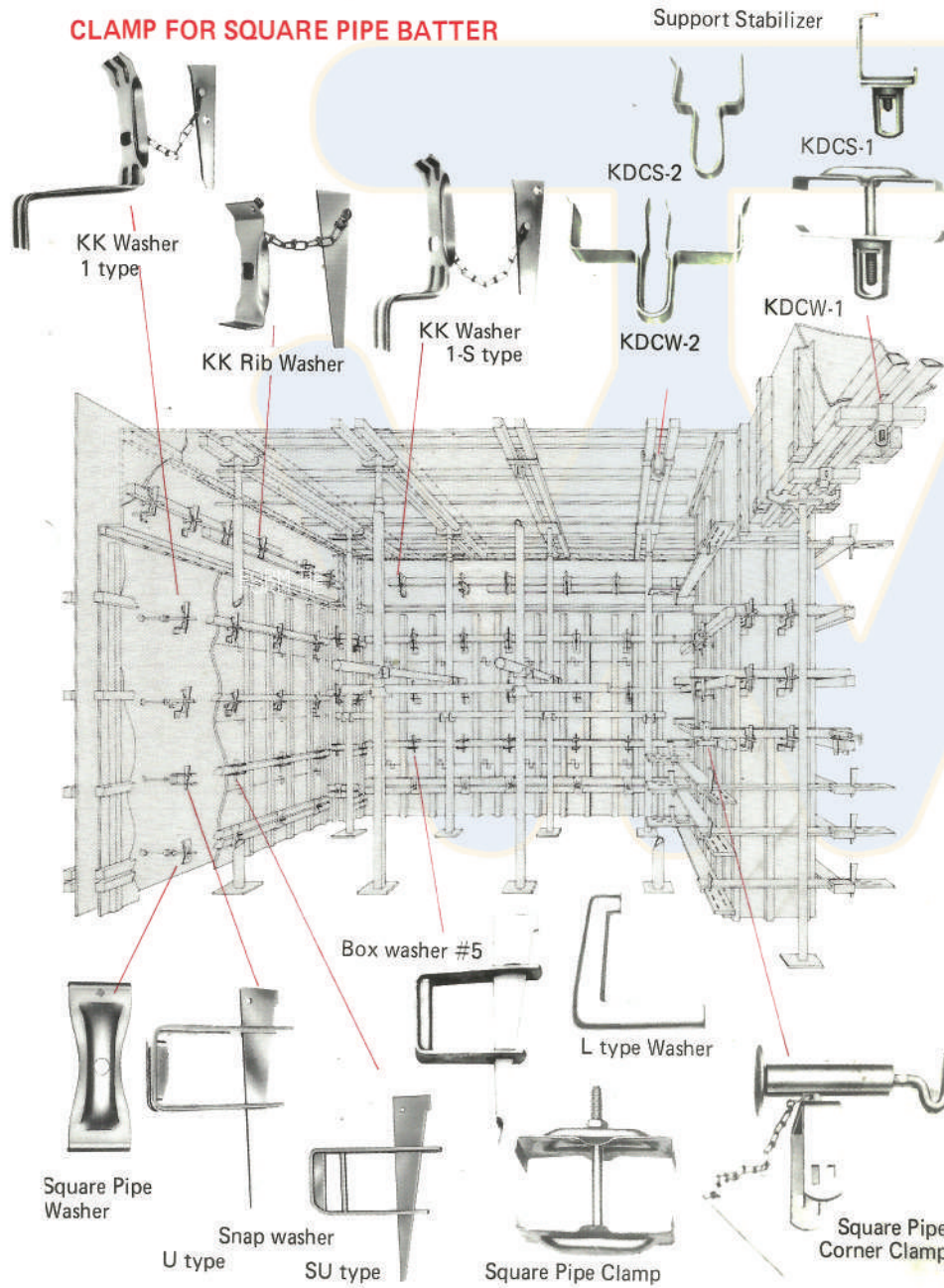

## TOOLS FOR FORM TIES



Box Spanner B



Box Spanner D



Form Tie Spanner



Slab-adjusting Hardware

# FORM TIE

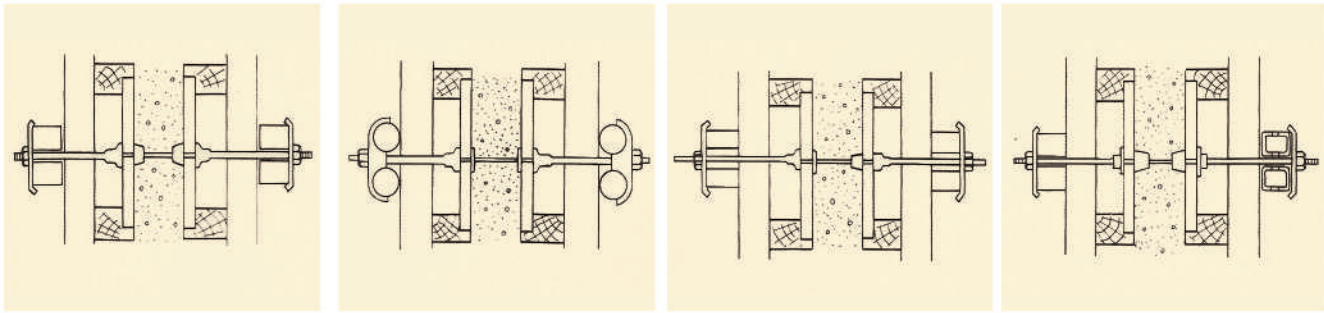

## FORMTIE Dimensional Diagrams

| Type   | L m/m | ℓ <sub>1</sub> m/m | Remarks  |                                 |
|--|-------|--------------------|--|---------------------------------|
| <b>FORMTIE C (Common to B, C and BC)</b><br> | 310   | 145                | $\phi_1 = W^{5/16}$<br>$W^{3/8}$<br>$\phi_2 = W^{1/2}$<br>with a nut |                                 |
|  | 250   | 145                |  |                                 |
|  | 210   | 120                |  |                                 |
|  | 180   | 95                 |  |                                 |
|  | 150   | 95                 |  |                                 |
| <b>FORMTIE D</b><br>                         | L m/m | ℓ <sub>1</sub> m/m | ℓ <sub>2</sub> m/m   | $\phi = W^{1/2}$<br>with a nut. |
|  | 360   | 120                | 80   |                                 |
|  | 300   | 120                | 80   |                                 |
|  | 250   | 120                | 80   |                                 |

### How to Order:

- Please mention size of FORMTIE which is the thickness of wale and stud plus 2 inches.
- Please specify  $W^{5/16}$  or  $W^{3/8}$  in accordance with inner unit dia. (Ex. FORMTIE 250 m/m,  $W^{5/16}$ )

## INNER UNIT Specification

| Type          | Dimensional Diagrams | Use   |
|---------------|----------------------|---|
| Inner Unit B  |                      | Both sides exposed.<br>$W^{5/16}$ $W^{3/8}$             |
| Inner Unit C  |                      | Both sides finished.<br>$W^{5/16}$                      |
| Inner Unit BC |                      | One side finished and other side exposed.<br>$W^{5/16}$ |
| Inner Unit D  |                      | Both sides exposed.<br>$W^{1/2}$                        |

**How to Order:** Please specify B, C, BC or D and wall thickness (Ex. Inner Unit B 250 m/m (Wall thickness))



## 1. TYPE B

| Panel          | Diagrams   |            | Remarks   |
|----------------|------------|------------|---|
|                | A (m/m)    | B          |   |
| Metal Form     | For Metal  | $W^{5/16}$ | a. There are two diameters for inner units<br>i. e. $W^{5/16}$ and $W^{3/8}$<br>b. A – Panel thickness<br>B – Inner unit diameter |
|                |            | $W^{3/8}$  |   |
| Ply Wood Panel | 12         | $W^{5/16}$ |   |
|                |            | $W^{3/8}$  |   |
|                | 16         | $W^{5/16}$ |   |
|                |            | $W^{3/8}$  |   |
| 24             | $W^{5/16}$ |            |   |
|                | $W^{3/8}$  |            |   |

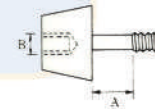

**How to Order:** Please specify concrete panel thickness (A) and inner unit diameter (B).  
 (Ex. Plastic Cone B 12 m/m x  $W^{5/16}$ )

## PLASTIC CONE FOR BEAM

|  |  |                   |  |
|--|--|-------------------|--|
|  |  | Metal             |  |
|  |  | 12 m/m            |  |
|  |  | 16 m/m            |  |
|  |  | 24 m/m<br>(A m/m) |  |

**How to Order:** Please specify panel thickness (A) and Inner Unit diameter (B).

## TYPE D

|  |                                    |
|--|------------------------------------|
|  | Inner Unit $W^{1/2}$ is only used. |
|--|------------------------------------|

**How to Order:** Plastic Cone D is O.K.

## TAPERED P CONE

|  |                                     |
|--|-------------------------------------|
|  | For the leaning panel construction. |
|--|-------------------------------------|

**How to Order:** Please specify panel thickness (A) Inner Unit diameter (B), and incline.

## BEDDING PLUG

|  |   |
|--|---|
|  | It is used to seal the hole which is made because the Cone is removed after the concrete has set. |
|--|---|

## ACCESSORY TOOLS

### FORMTIE Spanner

To be used to fasten FORMTIE and Inner Unit and remove them.



### Box Spanner D and B

To be used to remove Cone.



# HARDWARE FOR FORM TIE

Hardware for every type of batter is in stock

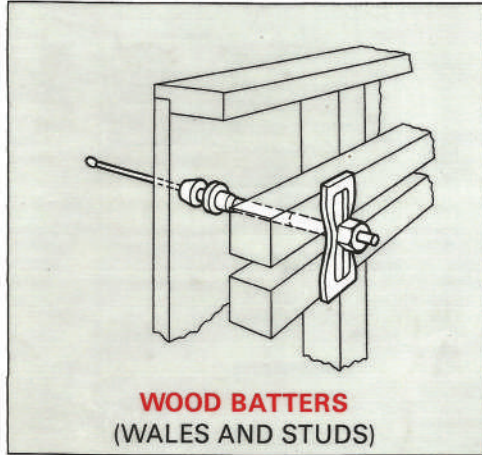

## FOR WOOD BATTERS

Flat Rib Washer

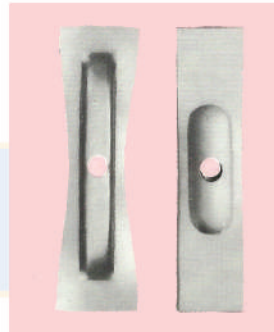

200×55

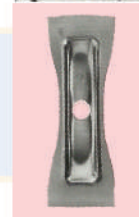

150×55

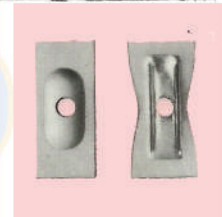

105 X 50

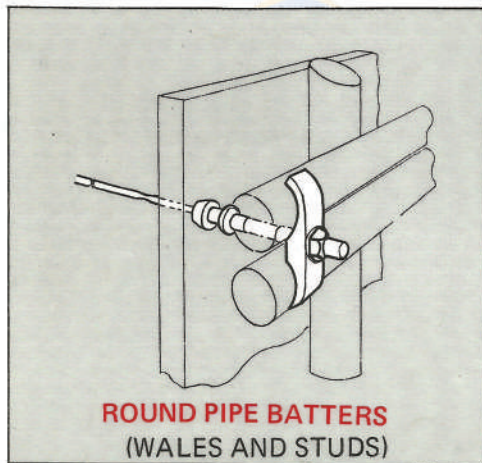

## FOR ROUND PIPE BATTERS



3-shape Rib Washer



KP Washer

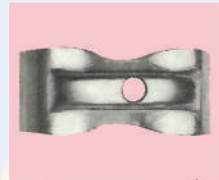

3-shape Rib Washer D



KP Washer SW

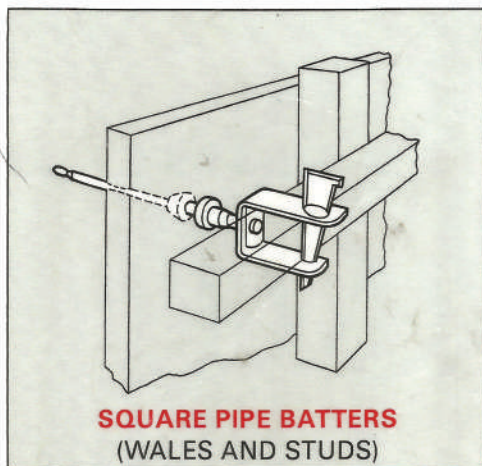

## FOR SQUARE PIPE BATTERS



Square Pipe Washer



Square Pipe Corner Clamp



KK Washer 1-S type



KK Rib Washer



Washer SU type

# TECHNICAL DATA OF FORM TIE

## MECHANICAL CHARACTERISTIC OF FORMTIE

### 1. Mechanical Properties of All Types of Inner Units

| Type | Dia   | Cross Sectional Area mm <sup>2</sup> | Rupture Strength kg/pce | Safe Working loads kg/pce | Breakage         |
|------|-------|--------------------------------------|-------------------------|---------------------------|------------------|
| B    | W5/16 | 34.3                                 | 2000                    | 1400                      | Threaded portion |
| C    | W5/16 | 34.3                                 | 2000                    | 1400                      | Threaded portion |
| BC   | W5/16 | 34.3                                 | 2000                    | 1400                      | Threaded portion |
| B    | W3/8  | 50.4                                 | 3000                    | 2100                      | ▲                |
| D    | W1/2  | 89.6                                 | 4000                    | 2800                      | ▲                |

▲ means FORMTIE Main Body, Head Part, Center-Rod, Threaded Part of Inner Unit, etc.

### 2. Allowable Strength of Inner Unit

When using steel as the material, the designing must be based on the strength within the yield point on the safe side. In general, the yield point of steel is considered to be within 70-80% of the rupture strength, but in case of the Inner Unit, because it is workhardened, the rupture strength and the yield point are almost the same. Therefore, to be on the safe side, 70% is the percentage to be considered.

## QUANTITY OF FORMTIE USED

To decide how many FORMTIE should be used, calculation has been made based on side pressure 2 t/m<sup>2</sup> (2 pieces of FORMTIE per 1 m<sup>2</sup> of vertical form) in accordance with JASS 5. Today, side pressure 6t/m<sup>2</sup> is used, largely due to mass production of plywood panels, concrete pumps and concrete.

The pressure of concrete on the form varies in accordance with concreting speed, slump, setting speed of concrete, tamping way of concrete and atmospheric temperature.

Therefore, the best way to estimate the side pressure is by taking into consideration all the conditions at the working site and decide the quantity of FORMTIE

Quantity of FORMTIE /per m<sup>2</sup>

| Type              | Side Pressure /m <sup>2</sup> | Quantity of FORMTIE /per m <sup>2</sup> |                    |                    |                    |                    |                    |
|-------------------|-------------------------------|---|--------------------|--------------------|--------------------|--------------------|--------------------|
|                   |                               | 2 t/m <sup>2</sup>                      | 3 t/m <sup>2</sup> | 4 t/m <sup>2</sup> | 5 t/m <sup>2</sup> | 6 t/m <sup>2</sup> | 7 t/m <sup>2</sup> |
| Inner Unit W 5/16 |                               | 1.42                                    | 2.14               | 2.85               | 3.57               | 4.28               | 5.00               |
| W 3/8             |                               | 0.95                                    | 1.42               | 1.90               | 2.38               | 2.85               | 3.33               |
| W 1/2             |                               | 0.71                                    | 1.07               | 1.42               | 1.78               | 2.14               | 2.50               |

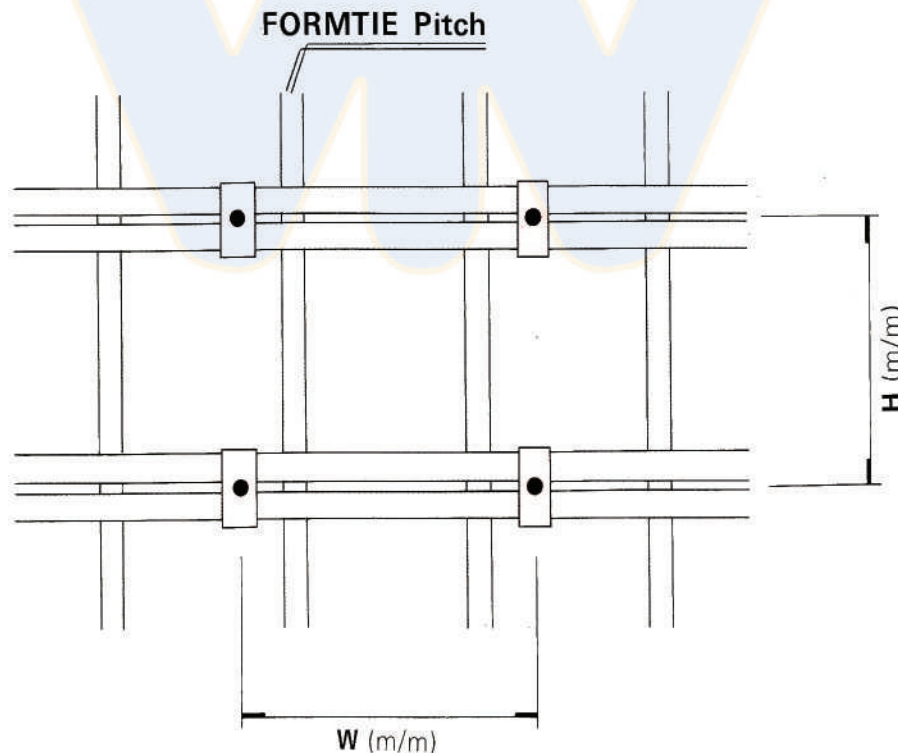

# TENSILE STRENGTH OF INNER UNIT

4 t/m<sup>2</sup>

| $\frac{W}{m} \backslash \frac{H}{m}$ | 500  | 550  | 600  | 650  | 700  | 750  | 800  | 850  | 900  |
|--------------------------------------|------|------|------|------|------|------|------|------|------|
| 500                                  | 1000 | 1100 | 1200 | 1300 | 1400 | 1500 | 1600 | 1700 | 1800 |
| 550                                  | 1100 | 1210 | 1320 | 1430 | 1540 | 1650 | 1760 | 1870 | 1980 |
| 600                                  | 1200 | 1320 | 1440 | 1560 | 1680 | 1800 | 1920 | 2040 | 2160 |
| 650                                  | 1300 | 1430 | 1560 | 1690 | 1820 | 1950 | 2080 | 2210 | 2340 |
| 700                                  | 1400 | 1540 | 1680 | 1820 | 1960 | 2100 | 2240 | 2350 | 2520 |
| 750                                  | 1500 | 1650 | 1800 | 1950 | 2100 | 2250 | 2400 | 2550 | 2700 |
| 800                                  | 1600 | 1760 | 1920 | 2080 | 2240 | 2400 | 2560 | 2720 | 2880 |
| 850                                  | 1700 | 1870 | 2040 | 2210 | 2380 | 2550 | 2720 | 2890 | 3060 |
| 900                                  | 1800 | 1980 | 2160 | 2340 | 2520 | 2700 | 2880 | 3060 | 3240 |

5 t/m<sup>2</sup>

| $\frac{W}{m} \backslash \frac{H}{m}$ | 500  | 550  | 600  | 650  | 700  | 750  | 800  | 850  | 900  |
|--------------------------------------|------|------|------|------|------|------|------|------|------|
| 500                                  | 1250 | 1375 | 1500 | 1625 | 1750 | 1875 | 2000 | 2125 | 2250 |
| 550                                  | 1375 | 1513 | 1650 | 1788 | 1925 | 2063 | 2200 | 2338 | 2475 |
| 600                                  | 1500 | 1650 | 1800 | 1950 | 2100 | 2250 | 2400 | 2550 | 2700 |
| 650                                  | 1625 | 1788 | 1950 | 2113 | 2275 | 2438 | 2600 | 2763 | 2925 |
| 700                                  | 1750 | 1925 | 2100 | 2275 | 2450 | 2625 | 2800 | 2975 | 3150 |
| 750                                  | 1875 | 2063 | 2250 | 2438 | 2625 | 2813 | 3000 | 3188 | 3375 |
| 800                                  | 2000 | 2200 | 2400 | 2600 | 2800 | 3000 | 3200 | 3400 | 3600 |
| 850                                  | 2125 | 2338 | 2550 | 2763 | 2975 | 3188 | 3400 | 3613 | 3825 |
| 900                                  | 2250 | 2475 | 2700 | 2925 | 3150 | 3375 | 3600 | 3825 | 4050 |

6 t/m<sup>2</sup>

| $\frac{W}{m} \backslash \frac{H}{m}$ | 500  | 550  | 600  | 650  | 700  | 750  | 800  | 850  | 900  |
|--------------------------------------|------|------|------|------|------|------|------|------|------|
| 500                                  | 1500 | 1650 | 1800 | 1950 | 2100 | 2250 | 2400 | 2550 | 2700 |
| 550                                  | 1650 | 1815 | 1980 | 2145 | 2310 | 2475 | 2640 | 2805 | 2970 |
| 600                                  | 1800 | 1980 | 2160 | 2340 | 2520 | 2700 | 2880 | 3060 | 3240 |
| 650                                  | 1950 | 2145 | 2340 | 2535 | 2730 | 2925 | 3120 | 3315 | 3510 |
| 700                                  | 2100 | 2310 | 2520 | 2730 | 2940 | 3150 | 3360 | 3570 | 3780 |
| 750                                  | 2250 | 2475 | 2700 | 2925 | 3150 | 3375 | 3600 | 3825 | 4050 |
| 800                                  | 2400 | 2640 | 2880 | 3120 | 3360 | 3600 | 3840 | 4080 | 4320 |
| 850                                  | 2550 | 2805 | 3060 | 3315 | 3700 | 3825 | 4080 | 4335 | 4590 |
| 900                                  | 2700 | 2970 | 3240 | 3510 | 3780 | 4050 | 4320 | 4590 | 4860 |

7 t/m<sup>2</sup>

| $\frac{W}{m} \backslash \frac{H}{m}$ | 500  | 550  | 600  | 650  | 700  | 750  | 800  | 850  | 900  |
|--------------------------------------|------|------|------|------|------|------|------|------|------|
| 500                                  | 1750 | 1925 | 2100 | 2275 | 2450 | 2625 | 2800 | 2975 | 3150 |
| 550                                  | 1925 | 2118 | 2310 | 2503 | 2695 | 2888 | 3080 | 3273 | 3465 |
| 600                                  | 2100 | 2310 | 2520 | 2730 | 2940 | 3150 | 3360 | 3570 | 3780 |
| 650                                  | 2275 | 2503 | 2730 | 2958 | 3185 | 3413 | 3640 | 3868 | 4095 |
| 700                                  | 2450 | 2695 | 2940 | 3185 | 3430 | 3675 | 3920 | 4165 | 4410 |
| 750                                  | 2625 | 2888 | 3150 | 3413 | 3675 | 3938 | 4200 | 4463 | 4725 |
| 800                                  | 2800 | 3080 | 3360 | 3640 | 3920 | 4200 | 4480 | 4760 | 5040 |
| 850                                  | 2975 | 3255 | 3570 | 3868 | 4165 | 4463 | 4760 | 5078 | 5355 |
| 900                                  | 3150 | 3465 | 3780 | 4095 | 4410 | 4725 | 5040 | 5355 | 5670 |

 W<sup>5/16</sup>

 W<sup>3/8</sup>

 W<sup>1/2</sup>

 High tensile W<sup>3/8</sup>



# TIE ROD FOR COLUMN

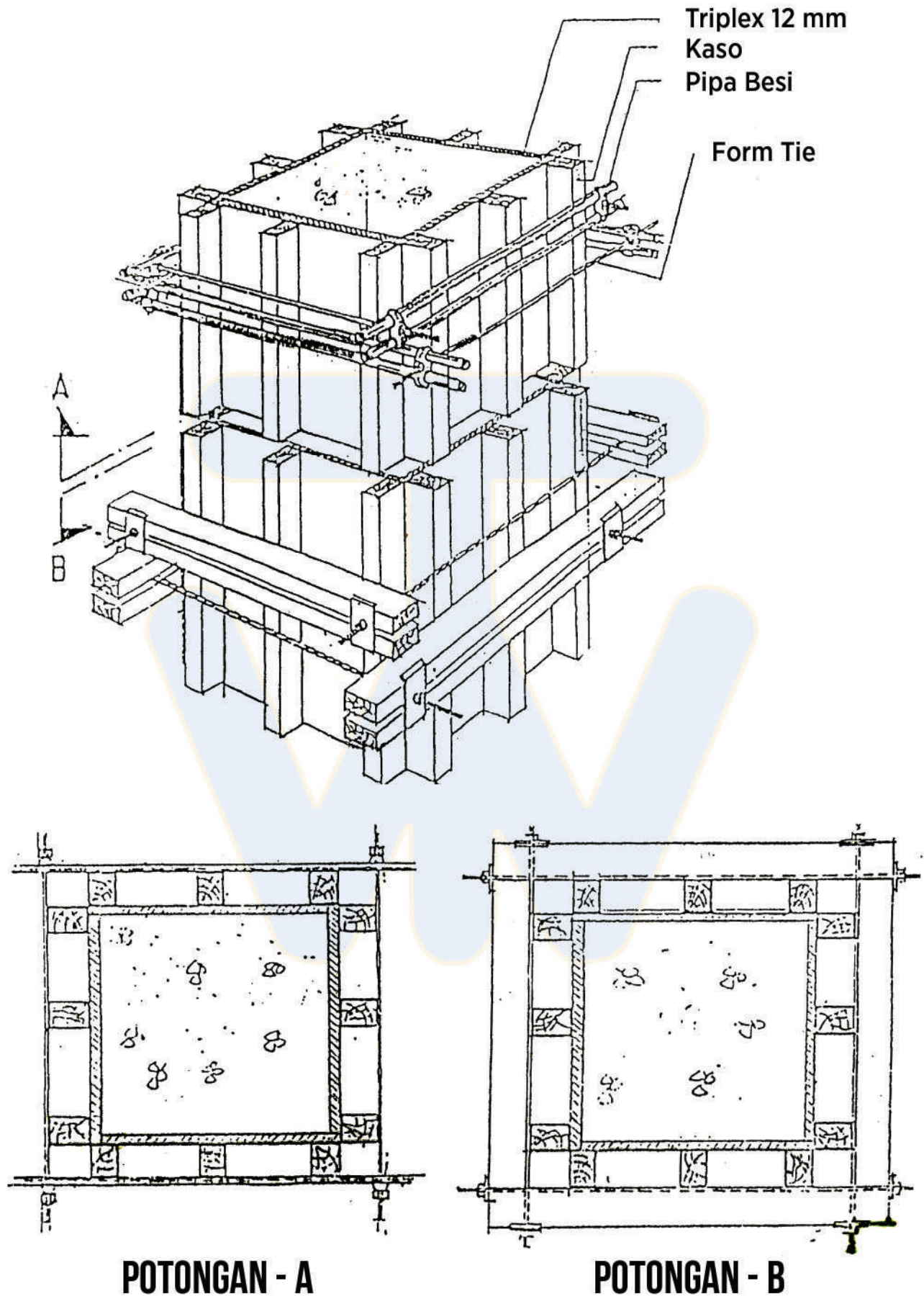

# TIE ROD

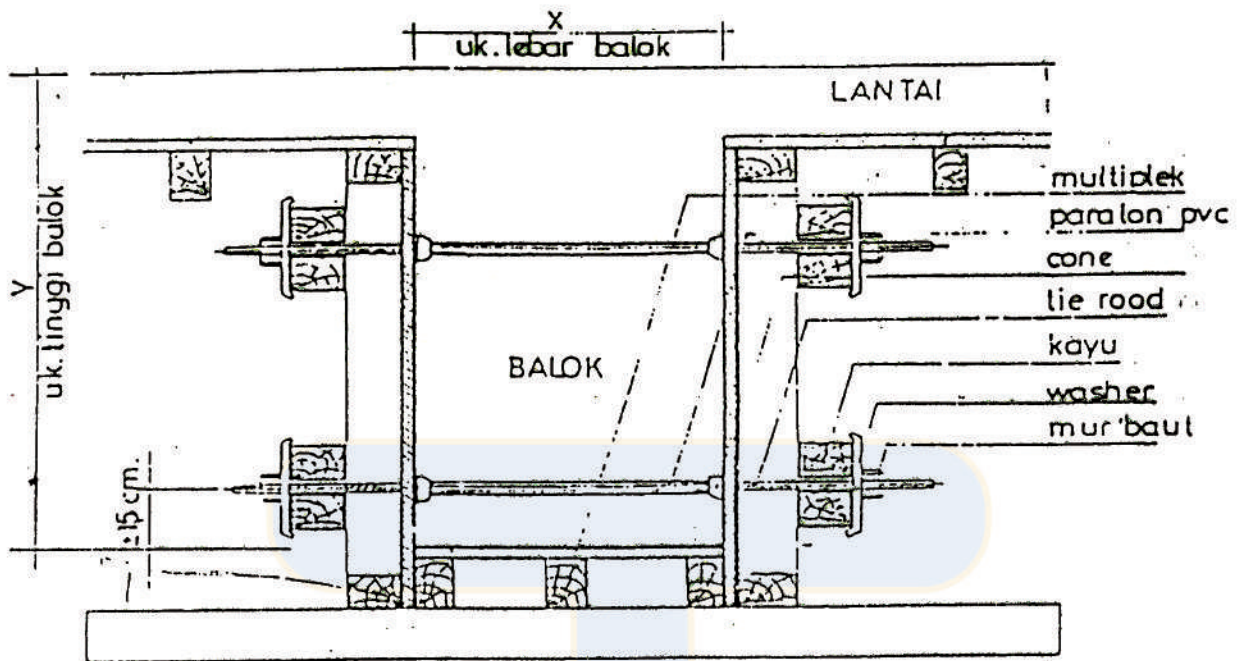

**PVC CONES D 20**



**WINGNUT 94**



**WINGNUT 92H**



**WINGNUT 92P**

# WALL JOINT

## Tie Rod DW 15/17

Not weldable!

All. load according to DIN 18216 = 20.5 klp (91 kN)



Special lengths

1.0/lt

1.5/m

030030

 6 m

## Counterplate



$4\frac{2}{4}'' \times 4\frac{2}{4}'' \times 4\frac{5}{6}'' \text{ } \varnothing 2\frac{1}{4}''$  (120 x 120 x 15  $\varnothing$  20 mm)

All. load according to DIN 18216 = 20.5 klp (91 kN)

3.5

1.6

030140

## Wing Nut

All. load according to DIN 18216 = 20.5 klp (91 kN)

0.9

0.4

030100



WN-92



WN-94



## Wedge KZ

For connection of Steel Wales with VARIO-Couplings or used with Tie Yoko

1.8

0.84

024240



## Wedge K

Used with Coupling compression Plate KDP.

0.9

0.4

024250

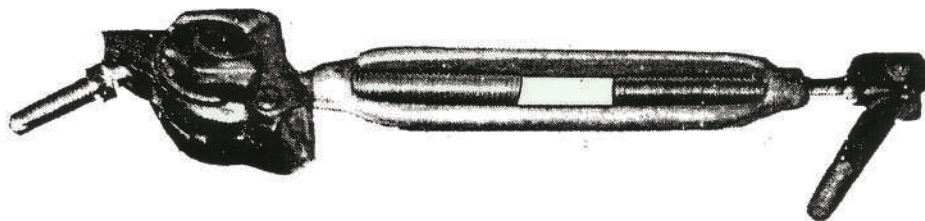

WALL JOINT & DINA SET

# TIE ROD

## CLIMBING CONES

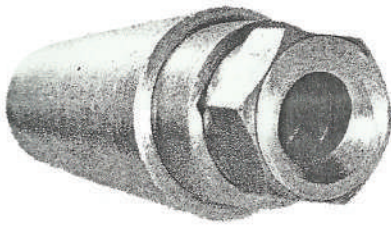

### Climbing Cones D 15 , with check-lever

length: 105 mm, SW 30, steel quality :  
9 SMnPb28k, to be used for climbing formwork  
allow, load 90 kN (DIN 18216)  
weight : 0,500 kg

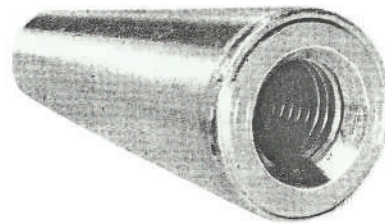

### Climbing Cone, with check-lever D 15/M24

length: 100 mm, SW 30, steel quality :  
9 SMnPb28k, for climbing formwork  
allow, load 90 kN (DIN 18216)  
weight : 0,460 kg

## STEEL CONES

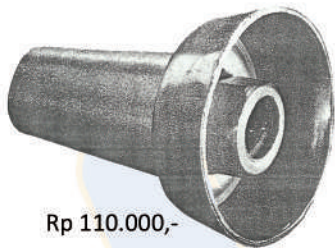

Rp 110.000,-

### Steel cone, with check-lever D 15/105\* plate with extra - wide base

length: 105 mm, SW 30, steel quality :  
9 SMnPb28k, with galvanized movable plate  
• max. 80mm, concrete overlap 55 mm,  
allow. load 90 kN (DIN 18216)  
weight: 0,670 kg

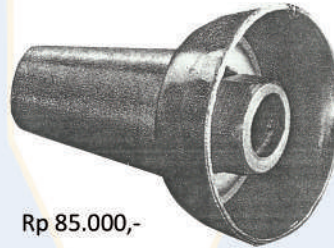

Rp 85.000,-

### Steel cone, with check-lever D 15/75\* large plate

length: 75 mm, SW 24, steel quality : C 35, 2ith  
galvanized movable plate • max. 63 mm. concrete  
overlap 40 mm, allow. load 90 kN (DIN 18216)  
weight: 0,340 kg

## HOW TO CALCULATE THE LENGTH OF TIES

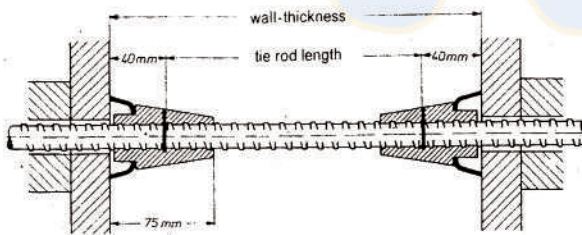

### Steel Cones D 15 / 75

length of middle tie =  
wall thickness less 80 mm

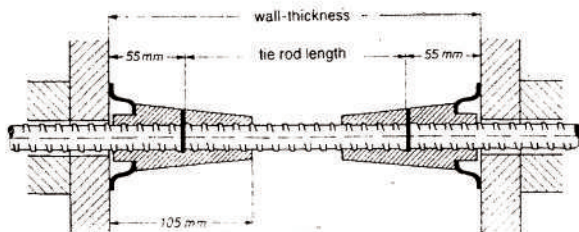

### Steel Cones D 15 / 105

length of middle tie =  
wall thickness less 110 mm

# FORMWORK - EQUIPMENT

## Formwork-Equipment Dywidag 15 mm $\emptyset$ in Use



**Connecting System D 15**  
Tie Rod D15  
Plastic Tube  
Counter Plates, reinf.  
Wing Nuts  
Plastic Cones



**Connecting System D 15**  
Tie Rod D 15  
Steel Cones  
Counter Plates, reinf.  
Wing Nuts

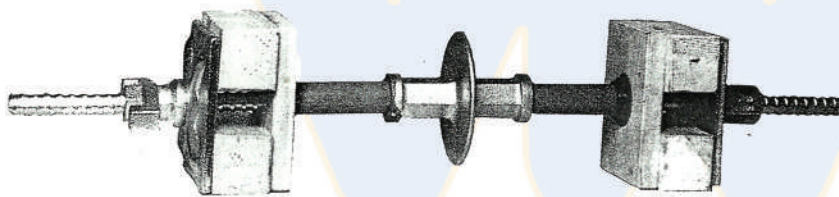

**Connecting System D 15**  
Tie Rod D15  
Waterstop-Center with large disc  
Plastic Tubes  
Counter Plates, reinf.  
Wing Nut  
Hexagonal Nut  
Plastic Cones

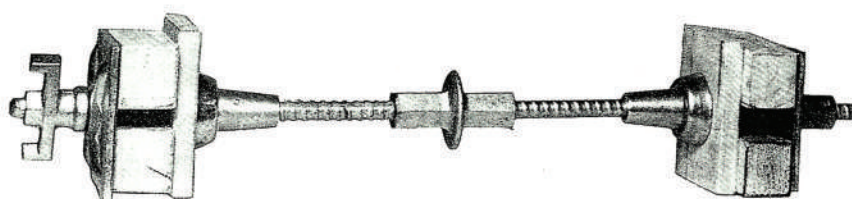

**Connecting System D 15**  
Tie Rod D 15  
Waterstop-Center with small disc  
Steel Cones  
Counter Plates, reinf.  
Wing Nut  
Hexagonal Nut

# PLASTIC WHEEL (PW)

Digunakan pada:  
Gedung : Lipslank; Dinding  
Jembatan : Dinding dan lain lain



DINDING

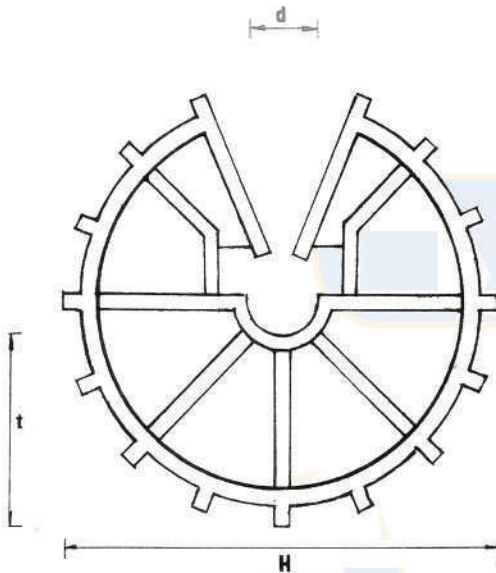
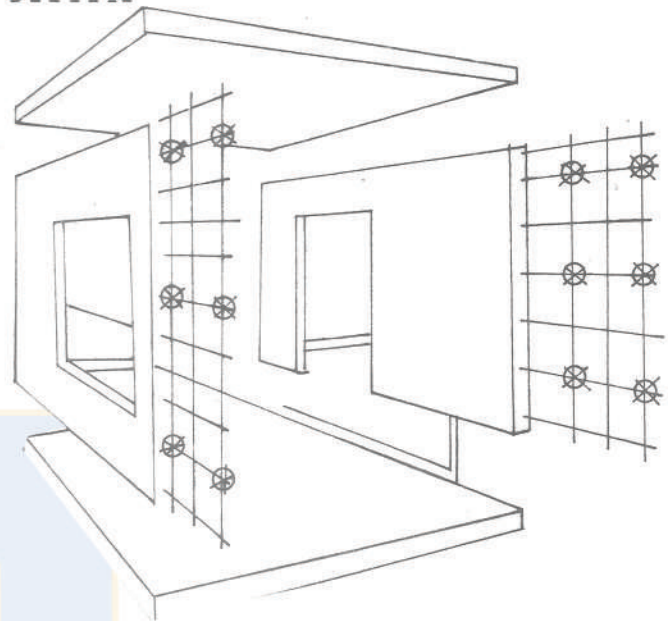

LISPLANK

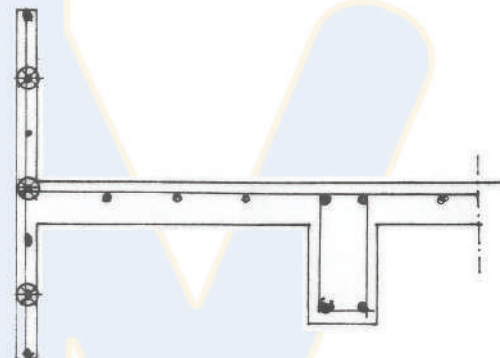

| TYPE     | (t)mm | (d)mm | (H)mm |
|----------|-------|-------|-------|
| PW 6X15  | 15    | 6     | 36    |
| 6X20     | 20    | 6     | 46    |
| PW 8X20  | 20    | 8     | 48    |
| 8X30     | 30    | 8     | 68    |
| 8X40     | 40    | 8     | 88    |
| PW 10X20 | 20    | 10    | 50    |
| 10X30    | 30    | 10    | 70    |
| 10X40    | 40    | 10    | 90    |
| PW 12X20 | 20    | 12    | 52    |
| 12X30    | 30    | 12    | 72    |
| 12X40    | 40    | 12    | 92    |
| 12X50    | 50    | 12    | 112   |
| 12X60    | 60    | 12    | 132   |
| PW 16X30 | 30    | 16    | 76    |
| 16X40    | 40    | 16    | 96    |
| 16X50    | 50    | 16    | 116   |
| 16X60    | 60    | 16    | 136   |
| 16X75    | 75    | 16    | 166   |
| PW 19X40 | 40    | 19    | 99    |
| 19X50    | 50    | 19    | 119   |
| 19X60    | 60    | 19    | 139   |
| 19X75    | 75    | 19    | 169   |
| 19X95    | 95    | 19    | 209   |



**KETERANGAN :**

[t] : TEBAL SISI BETON

[d] : DIAMETER BESI

[H] : JUMLAH TOTAL TEBAL BETON

Digunakan untuk menyangga  
pembesian horizontal yang berat pada  
lantai, fondasi, dll

# HEAVY DUTY PLASTIC CHAIR (HDPC)

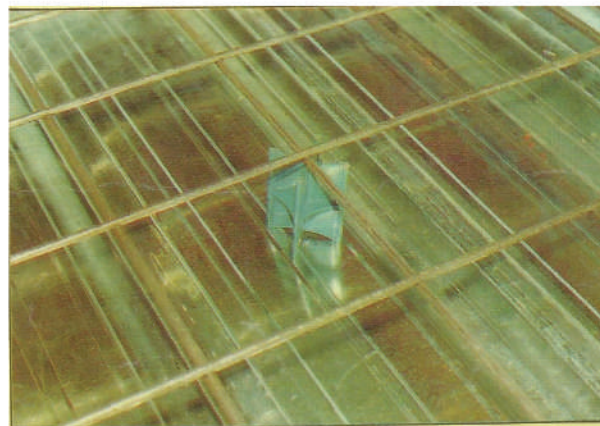
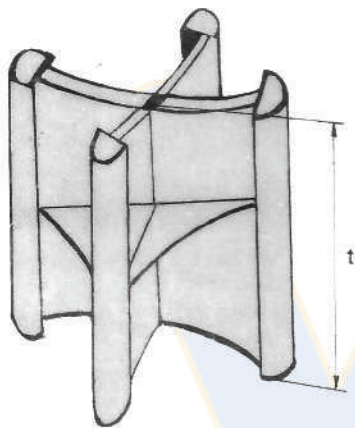
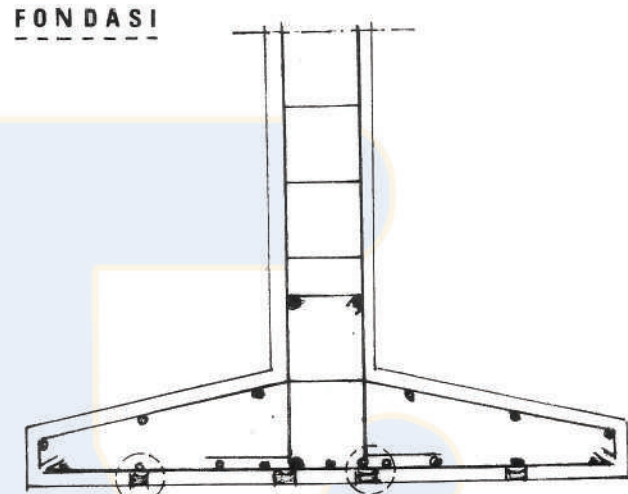
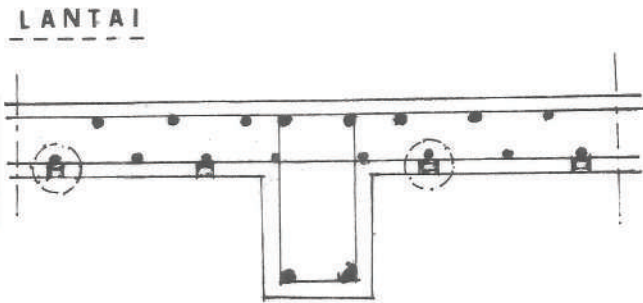
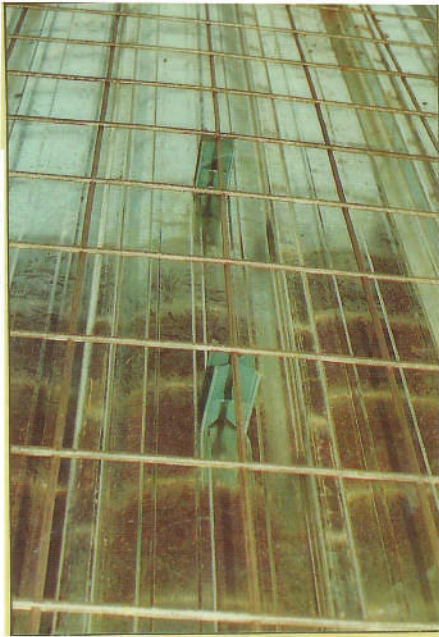

| TYPE | TEBAL BESI<br>BETON (t) mm |     |
|------|----------------------------|-----|
| HDPC | 20                         | 20  |
|      | 30                         | 30  |
|      | 40                         | 40  |
|      | 50                         | 50  |
|      | 60                         | 60  |
| HDPC | 70                         | 70  |
|      | 80                         | 80  |
|      | 90                         | 90  |
|      | 100                        | 100 |
|      | 110                        | 110 |
| HDPC | 130                        | 130 |
|      | 150                        | 150 |
|      | 170                        | 170 |

# PLASTIC CHAIR (PC)

Digunakan untuk menyangga pembesian horizontal pada lantai, fondasi, dll

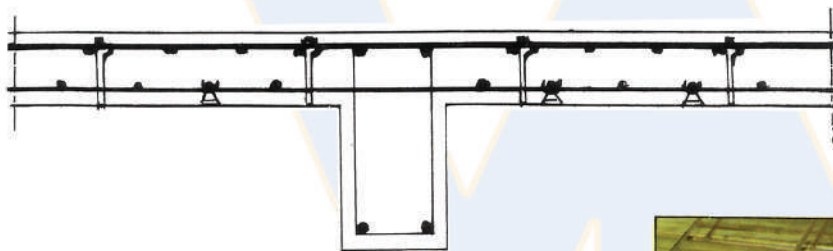
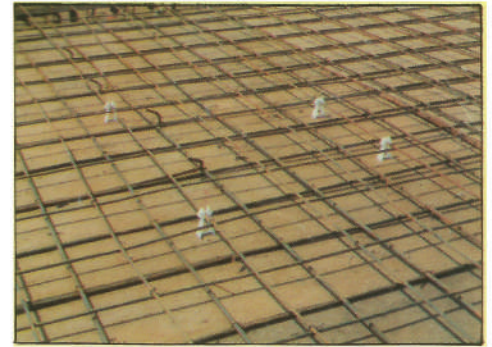
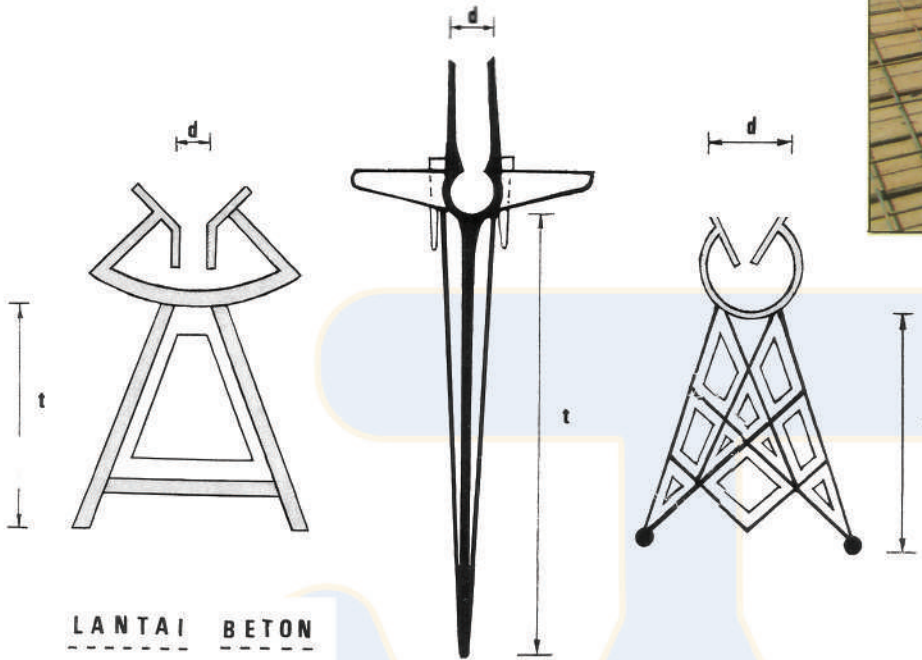

| TYPE  | [t] mm | [d] mm |
|-------|--------|--------|
| PC 10 | 10     | 6 - 12 |
|       | 15     | 6 - 12 |
|       | 25     | 6 - 12 |
|       | 30     | 6 - 12 |
|       | 40     | 6 - 12 |
| PC 50 | 50     | 6 - 12 |
|       | 60     | 6 - 12 |
|       | 70     | 6 - 12 |
|       | 75     | 6 - 12 |
|       | 85     | 6 - 12 |
| PC 90 | 90     | 6 - 12 |
|       | 95     | 6 - 12 |

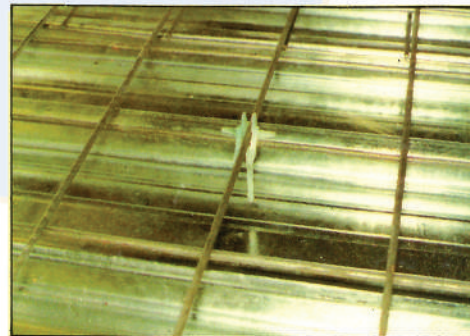

# NAILS MOUNTED STEEL INSERT

## POPEYE-2 for CEILING WORKS

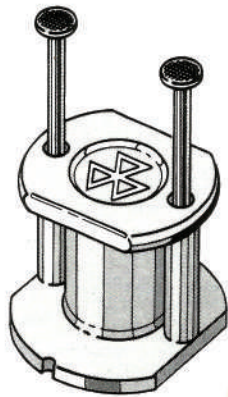

*Economical Type!!*

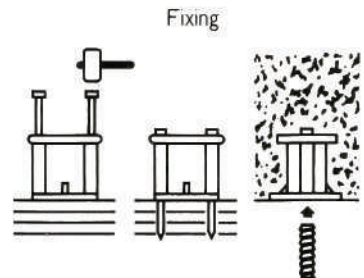
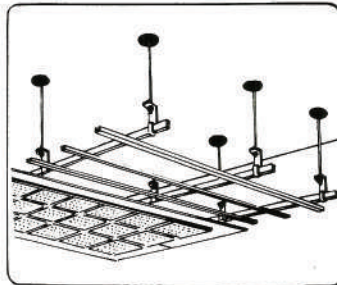

| Depth  | Size     | Item   | Carton   | Pull-out Strength |
|--------|----------|--------|----------|-------------------|
| 20(mm) | 3/8 x 20 | P-3020 | 500(pcs) | 500~(kgf)         |

\* SAFE for Fire.

\* EASY & SIMPLE Fixing.

\* Depth (mm) means length in concrete.

## APOLLO-2 for MEDIUM DUTY FACILITIES

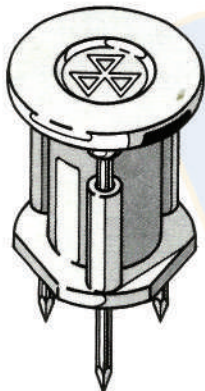

\* Fire-Protection System,

\* Electrical-Works, etc.....

| Depth  | Size     | Item   | Carton   | Pull-out Strength |
|--------|----------|--------|----------|-------------------|
| 25(mm) | 3/8 x 25 | A-3025 | 500(pcs) | 800~(kgf)         |

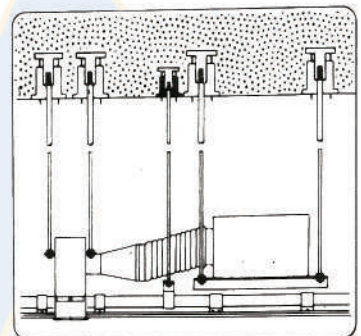

## SPIKER for HEAVY-DUTY FACILITIES

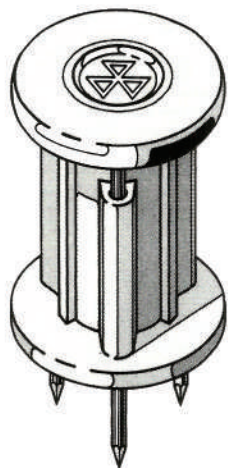

\* Air-Conditioning System,

\* Plumbing, Sanitary Works, etc.....

| Depth  | Size     | Item   | Carton   | Pull-out Strength |
|--------|----------|--------|----------|-------------------|
| 40(mm) | 3/8 x 40 | S-3040 | 400(pcs) | 1500~(kgf)        |
| 45     | 1/2 x 45 | 4045   | 250      | 2500~             |

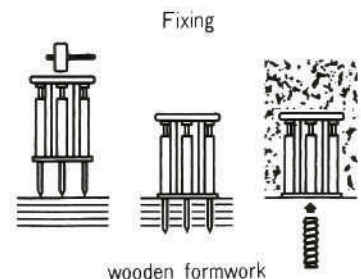

# PLASTIC CHAIR

## COLOR STRONG

Supplied with Hardened Engineering Plastic NAIL .....easy nail-off by hammer.....

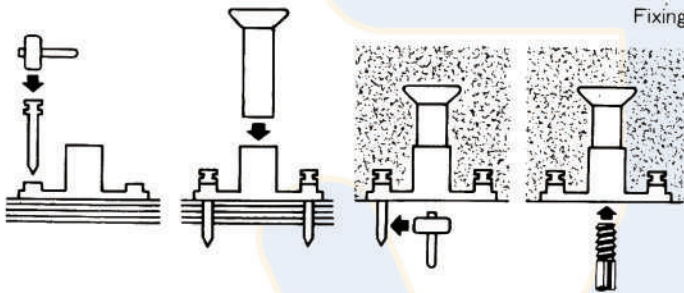
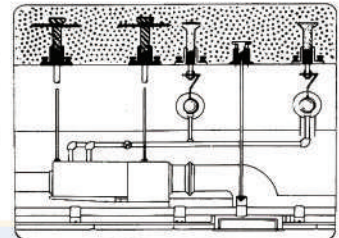
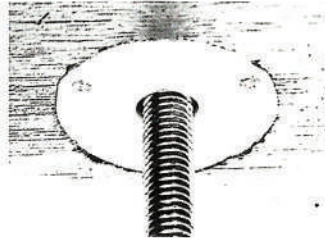
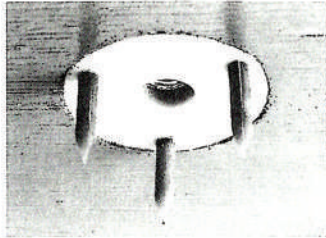
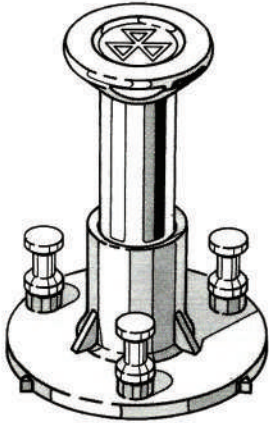

| Depth  | Size                    | Item    | Carton   | Pull-out Strength |
|--------|-------------------------|---------|----------|-------------------|
| 30(mm) | $\frac{3}{8} \times 30$ | CS-3030 | 400(pcs) | 1200~(kgf)        |
| 40     | $\frac{3}{8} \times 40$ | 3040    | 400      | 1500~             |
| 40     | $\frac{1}{2} \times 40$ | 4040    | 150      | 2000~             |
| 55     | $\frac{1}{2} \times 55$ | 4055    | 150      | 2500~             |
| 60     | $\frac{5}{8} \times 60$ | 5060    | order    | 4000~             |
| 80     | $\frac{5}{8} \times 80$ | 5080    | 100      | 4500~             |
| 80     | $\frac{3}{4} \times 80$ | 6080    | order    | 5500~             |

## PANESERT

FOR SCAFFOLDING, SUSPENSION, TEMPORARY ANCHORING, ETC....

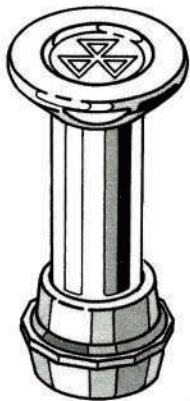

Example of application at tunnel.

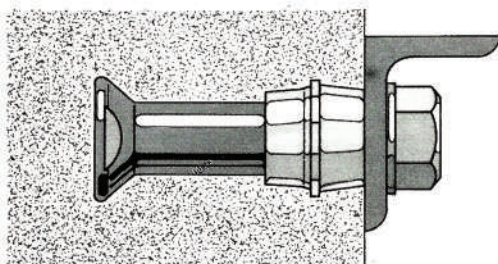

| Depth  | Size                     | Item    | Carton   | Pull-out Strength | Shear Tensile |
|--------|--------------------------|---------|----------|-------------------|---------------|
| 30(mm) | $\frac{3}{8} \times 30$  | PN-3030 | 500(pcs) | 1500~(kgh)        | 1600~(kg)     |
| 45     | $\frac{1}{2} \times 45$  | 4045    | 250      | 2500~             | 3000~         |
| 60     | $\frac{1}{2} \times 60$  | 4060    | 200      | 3500~             | 3000~         |
| 65     | $\frac{5}{8} \times 65$  | 5065    | 150      | 5000~             | 4500~         |
| 85     | $\frac{5}{8} \times 85$  | 5085    | 100      | 5500~             | 4500~         |
| 85     | $\frac{3}{4} \times 85$  | 6085    | 50       | 6000~             | 6000~         |
| 100    | $\frac{3}{4} \times 100$ | 6100    | 50       | 6000~             | 6000~         |

\*Depth means length in concrete.

# STILL INSERT

## COLOR HOLE

Reusable screw-attachment for reusable wooden form-work.  
 Reusable Attachment removed with Formwork.  
 Save cost of nail-off.

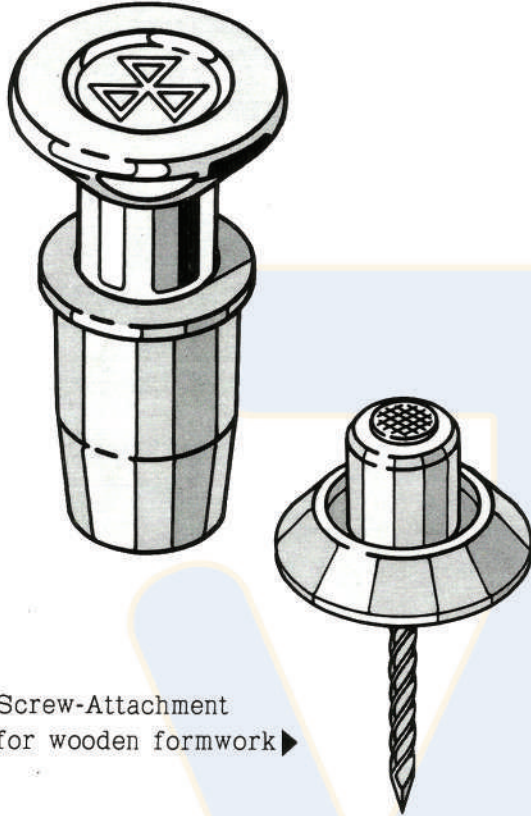

Screw-Attachment  
for wooden formwork ▶

just hammer and screw-in.

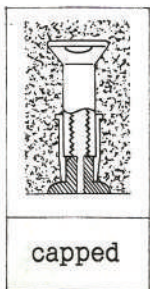
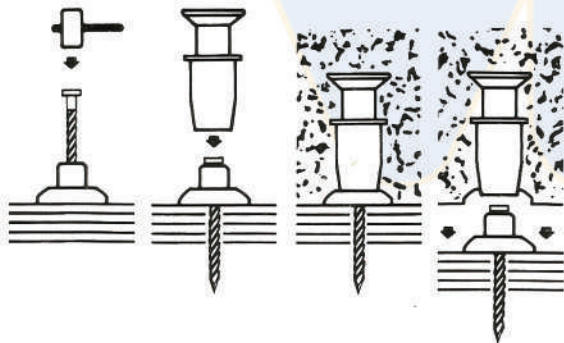

◀ Attachment can be used  
as cover of hole.



Good out-looking of concrete-surface

| Depth  | Size                    | Item    | Carton   | Pull-out Strength |
|--------|-------------------------|---------|----------|-------------------|
| 40(mm) | $\frac{3}{8} \times 40$ | CH-3040 | 500(pcs) | 1500~(kgf)        |
| 60     | $\frac{1}{2} \times 60$ | 4060    | 250      | 2800~             |

### APPLICATION

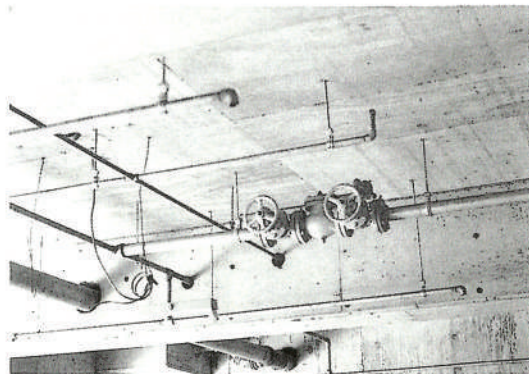
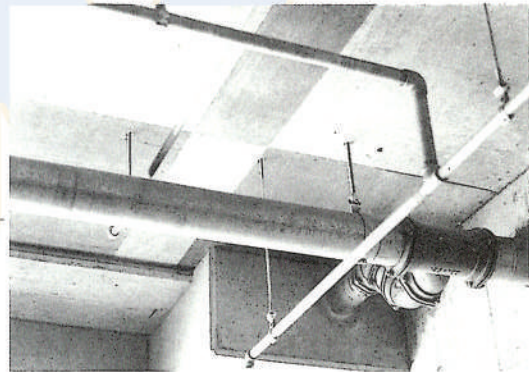

# INSTALLATION

① Set the screw attachment for wooden formwork.

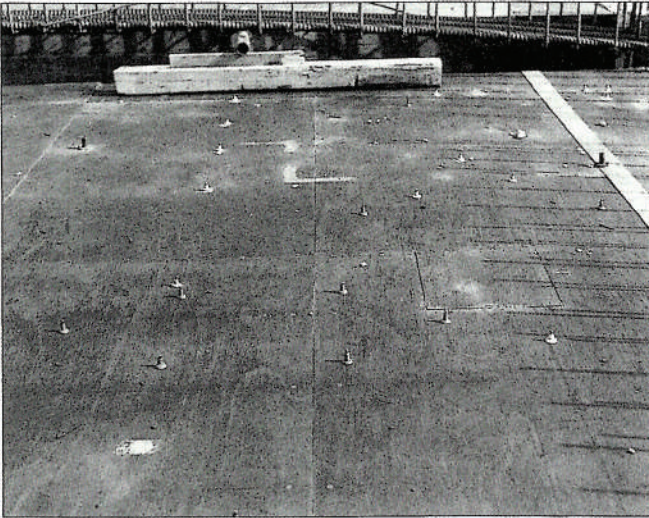

④ Put in the INSERT for screw attachment.

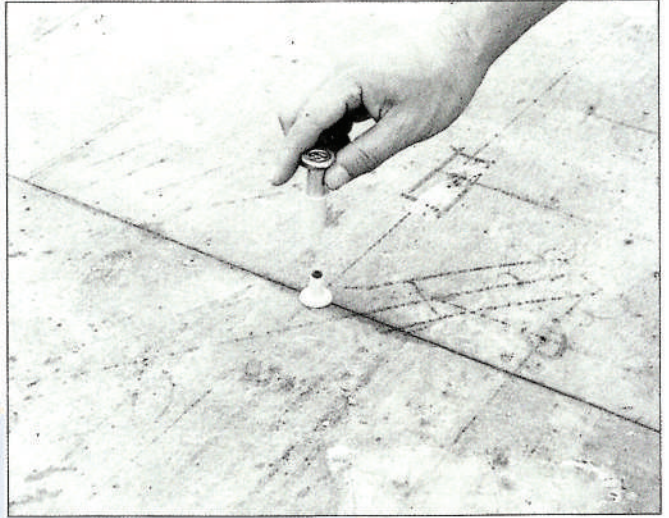

② Installed the screw attachment.

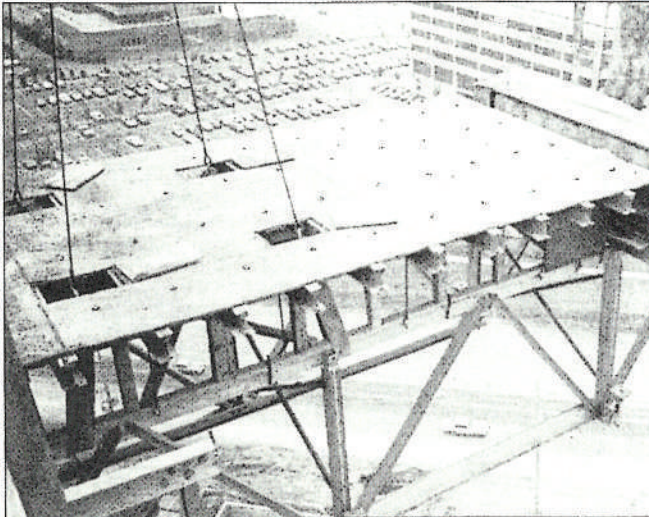

⑤ Set finished both reinforcing rod and INSERT.



③ Set up reinforcing rod.

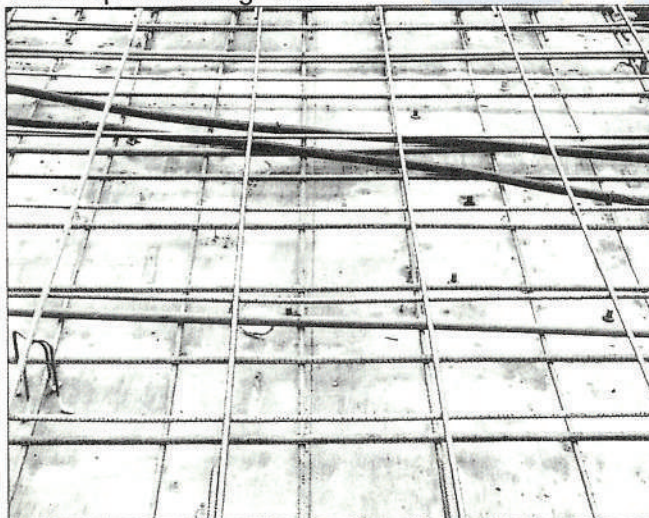

⑥ Disjoint the wooden formwork and set the bolt.

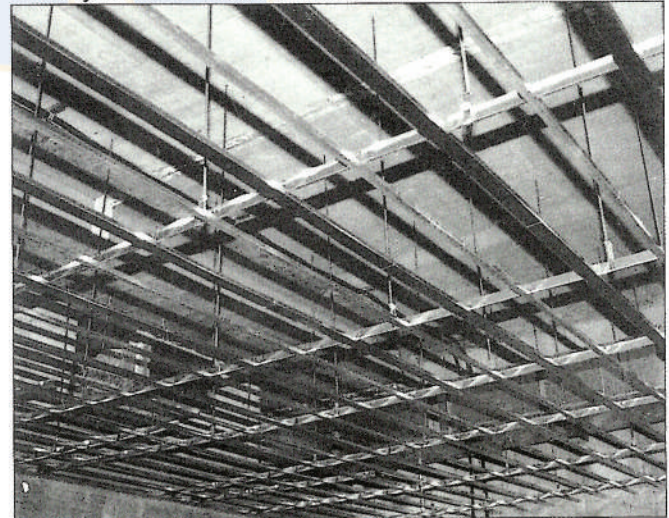

# CONSTRUCTION USED DECK-PLATE

for thick Deck-plate

## PLATE HANGER

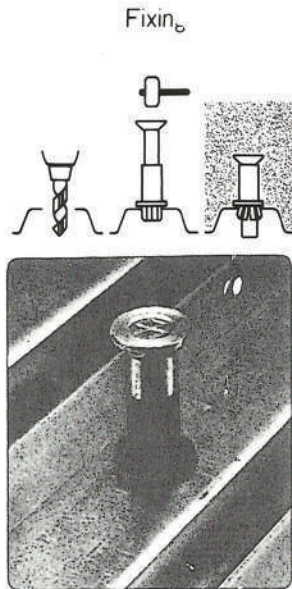
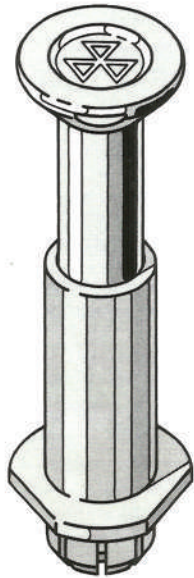

| Depth  | Size                    | Item    | Carton   | Drill    | Pull-out Strength |
|--------|-------------------------|---------|----------|----------|-------------------|
| 30(mm) | $\frac{3}{8} \times 40$ | PH-3030 | 500(pcs) | 15.0(mm) | 800~(kgf)         |
| 40     | $\frac{3}{8} \times 65$ | 3040    | 300      | 15.0     | 1500~             |
| 50     | $\frac{1}{2} \times 80$ | 4050    | 100      | 21.0     | 2500~             |

for FACILITIES

## SPRING HANGER

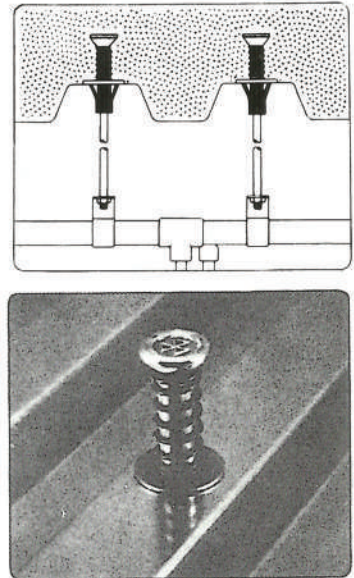
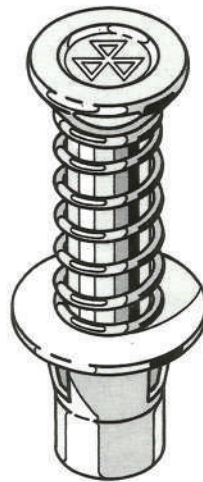

Effective as EARTH, too.

| Depth  | Size                    | Item    | Carton   | Drill    | Pull-out Strength |
|--------|-------------------------|---------|----------|----------|-------------------|
| 40(mm) | $\frac{3}{8} \times 60$ | SH-3040 | 250(pcs) | 16.0(mm) | 1500~(kgf)        |
| 55     | $\frac{1}{2} \times 85$ | 4055    | 100      | 22.0     | 2500~             |

for CEILING WORKS

for thick Deck-plate

## DECK PUNCH

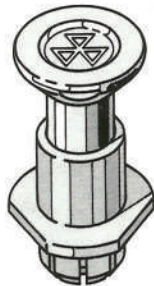
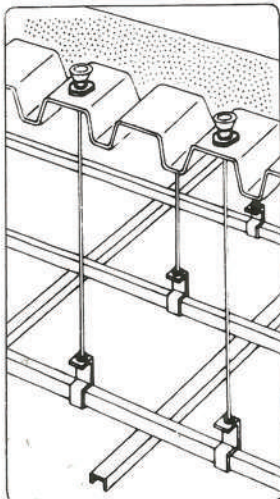

| Depth  | Size                    | Item    | Carton   | Drill    | Pull-out Strength |
|--------|-------------------------|---------|----------|----------|-------------------|
| 20(mm) | $\frac{1}{4} \times 30$ | DP-2020 | 500(pcs) | 12.0(mm) | 300~(kgf)         |
| 20     | $\frac{3}{8} \times 30$ | 3020    | 500      | 15.0     | 500~              |

for thin deck-plate

## SPRING DECK PUNCH

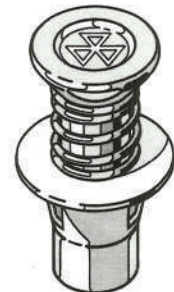
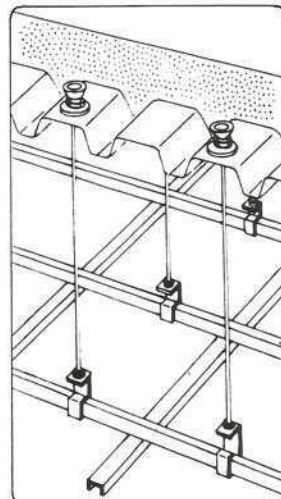

| Depth  | Size                    | Item    | Carton   | Drill    | Pull-out Strength |
|--------|-------------------------|---------|----------|----------|-------------------|
| 20(mm) | $\frac{1}{4} \times 40$ | KP-2020 | 500(pcs) | 13.0(mm) | 300~(kgf)         |
| 20     | $\frac{3}{8} \times 40$ | 3020    | 500      | 16.0     | 500~              |

# TEST REPORT

## PULL OUT STRENGTH

| ITEMS              | SIZE | DEPTH | BREAKING LOAD | BREAKAGE OF                                  | REMARKS   |      |
|--------------------|------|-------|---------------|--|---|------|
| SPIKER             | 3/8  | 40mm  | 1,840kgf      | Fracture of breakage on the part of Concrete | Tested by;<br>Concrete pressure<br>190kgf./cm <sup>2</sup><br><br>Material of Insert:<br>JIS standard<br>G-3539<br><br>*Breakage figure<br>does not mean<br>Safety-factor |      |
|                    | 1/2  | 45    | 2,910         |  |   |      |
| COLOR HOLE         | 3/8  | 40    | 1,900         |  |   |      |
|                    | 1/2  | 60    | 3,350         |  |   |      |
| APOLLO             | 3/8  | 25    | 900           |  |   |      |
| POPEYE             | 3/8  | 20    | 770           |  |   |      |
| PLATE HANGER       | 3/8  | 30    | 1,190         |  |   |      |
|                    | 3/8  | 40    | 1,910         |  |   |      |
|                    | 1/2  | 50    | 2,680         |  |   |      |
| DECK PUNCH         | 3/8  | 20    | 560           |  |   |      |
| COLOR STRONG       | 3/8  | 30    | 1,280         |  |   | Bolt |
|                    | 3/8  | 40    | 1,850         |  |   |      |
|                    | 1/2  | 40    | 2,750         |  |   |      |
|                    | 1/2  | 55    | 3,230         |  |   |      |
|                    | 5/8  | 60    | 5,200         |  |   |      |
|                    | 5/8  | 80    | 6,040         |  |   |      |
| COLOR STRONG CROSS | 3/8  | 80    | 3,010         |  |   |      |
|                    | 1/2  | 100   | 5,050         |  |   |      |
| SLIDART            | 3/8  | 30    | 2,300         | Concrete                                     |   |      |
|                    | 1/2  | 40    | 2,340         |  |   |      |

## SHEAR TENSILE

| TEST SPECIMEN | THREAD | SHEAR (kgf) | SHEAR  | REMARKS  |
|---------------|--------|-------------|--------|--|
| 12φ×l30m/m    | M6     | 1,690       | Bolt   | Material of Insert:<br>JIS Standard G-3539<br><br>Tested by Japanese Authority,<br>JAPAN TESTING CENTER FOR<br>CONSTRUCTION MATERIALS<br><br>Test Method:<br>20 Tons Universal Testing<br>Machine and Stainless Steel<br>Bolt (SUS-304). |
|               | "      | 1,700       |        |  |
|               | "      | 1,690       |        |  |
| 12φ×l30m/m    | M8     | 2,660       |        |  |
|               | "      | 2,650       |        |  |
|               | "      | 2,650       |        |  |
| 12φ×l30m/m    | 3/8    | 2,390       | Insert |  |
|               | "      | 2,320       |        |  |
|               | "      | 2,460       |        |  |
| 17φ×l40m/m    | M12    | 6,710       |        |  |
|               | "      | 6,510       |        |  |
|               | "      | 5,900       |        |  |
| 17φ×l80m/m    | 1/2    | 5,050       |        |  |
|               | "      | 5,060       |        |  |
|               | "      | 5,050       |        |  |
| 22φ×l80m/m    | 5/8    | 8,000       |        | Thread   |
|               | "      | 8,120       |        |  |
|               | "      | 8,600       |        |  |
| 22φ×l80m/m    | M16    | 8,560       |        |  |
|               | "      | 7,510       |        |  |
|               | "      | 8,500       |        |  |

JAPAN TESTING CENTER  
FOR CONSTRUCTION MATERIALS

*Takeshi Nagasawa*

Takeshi Nagasawa  
Chief Director

# SCAFFOLDING

## MAIN FRAME



MF 1219  
MF 1217  
MF 1215



## CROSS BRACE

| CODE   | A     | B     | C     |
|--------|-------|-------|-------|
| X-1812 | 1.829 | 1.219 | 1.219 |
| X-1512 | 1.524 | 1.219 | 1.219 |
| X-1212 | 1.219 | 1.219 | 1.219 |
| X-1809 | 1.829 | 914   | 914   |
| X-1509 | 1.524 | 914   | 914   |
| X-1209 | 1.219 | 914   | 914   |
| X-1806 | 1.829 | 610   | 610   |
| X-1506 | 1.524 | 610   | 610   |
| X-1206 | 1.219 | 610   | 610   |

## LADDER FRAME

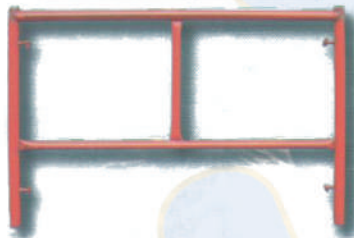

LF 1212  
LF 1209  
LF 1205

## CAT WALK



A. 1850

## HORIZONTAL FRAME



H-1812 - 1.050  
H-1814 - 450

## STAIR



T 219  
T 217

## JOIN PIN



A. 20



# SCAFFOLDING



ADJUSTABLE BEAM

A. AB 2238 - 2200 - 3800 MM

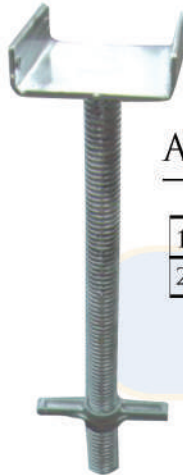

ADJUSTABLE U-HEAD

1. UH 40

2. UH 60



ADJUSTABLE BASE

1. JB 40

2. JB 60



1. TIE ROD 15/17

2. WN -94

PIPE SUPPORT

| MODEL   | HEIGHT CLOSED | HEIGHT EXTENDED |
|---------|---------------|-----------------|
| TS - 50 | 1,550 MM      | 2,750 MM        |
| TS - 60 | 1,850 MM      | 3,050 MM        |
| TS - 70 | 2,150 MM      | 3,350 MM        |
| TS - 90 | 2,700 MM      | 3,900 MM        |



SWIVEL CLAMP / RIGHT ANGLE CLAMP

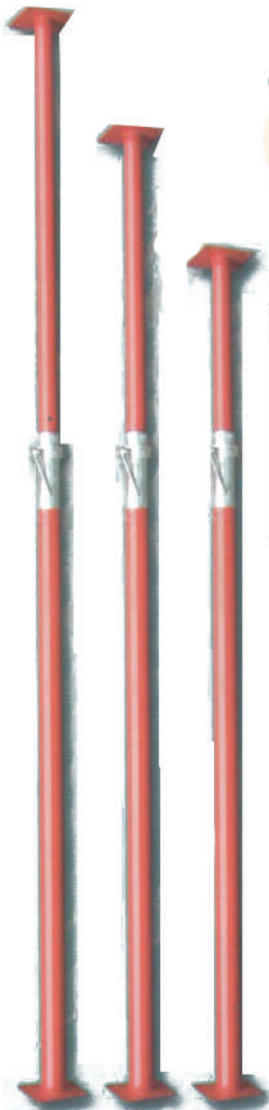

# TECHNICAL DATA

Frames are manufactured from high tensile structural carbon steel with main load-bearing members having an outside diameter of 42.7mm (1 1/4") and a wall thickness of 2.4mm (tensile strength of 51kg/mm<sup>2</sup>)

## LOAD TESTS

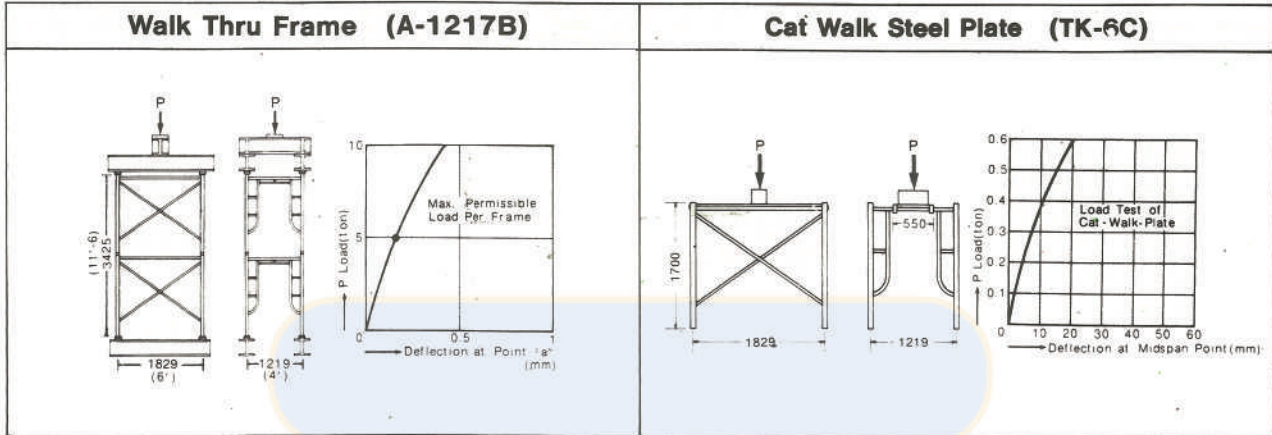

## MAXIMUM LEG LOADS (Safety factor: 2)

- 2,500 kg per leg — Frame A-1217B, A-1217A, A-917A
- 2,250 kg per leg — Frame A-1219
- 1,750 kg per leg — Frame A-717S, A-617S

## SAFE WORKING LOADS ON JACK COMPONENTS (Safety factor: 3.5)

| AJ-40 | AJ-65 | AJ-40H | AJ-65H | JJ-80 |
|-------|-------|--------|--------|-------|
|       |       |        |        |       |

## REDUCTION IN STRENGTH, DEPENDING UPON POSITIONS WHERE FRAME LOAD IS APPLIED

| Point of load            |     |      |      |    |      |       |       |
|--------------------------|-----|------|------|----|------|-------|-------|
| Max load per frame p max | 10t | 9.1t | 7.5t | 5t | 3t   | 2.25t | 2.25t |
| Allowable load           | 5t  | 3.5t | 3t   | 2t | 1.2t | 1t    | 1t    |

(Note) For load point, square pipe material 100mm x 100mm is used.



# SCAFFOLDING FOR CONSTRUCTIONS

## ROLLING TOWER

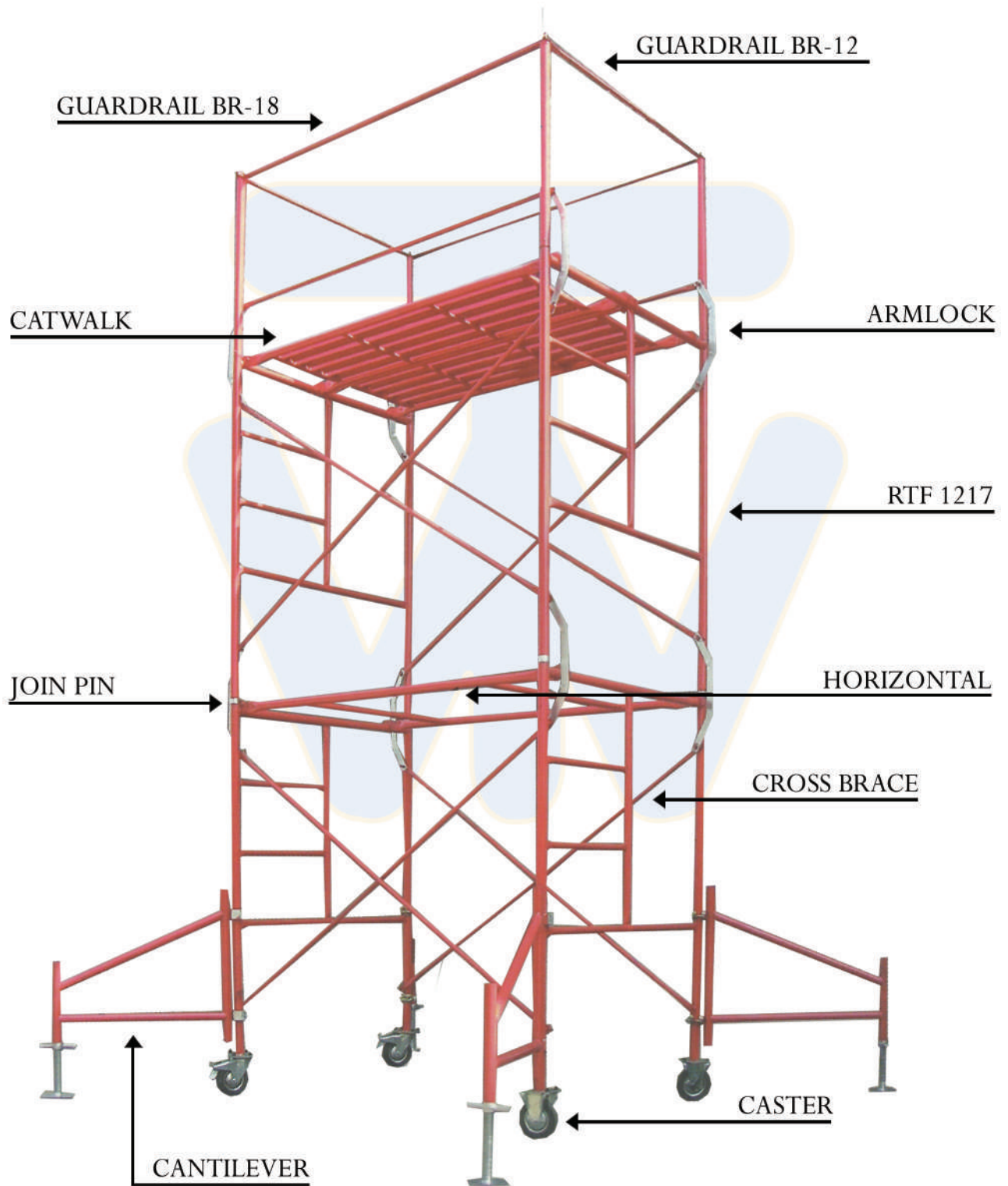



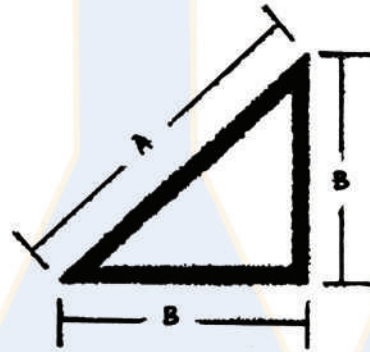

# CORNER CHAMFER

**LENGTH : 2 METERS**

| ITEM  | A    | B      | PRICE PER PC. (Rp) |
|-------|------|--------|--------------------|
| KT-15 | 15mm | 10.6mm | 17.500             |
| KT-20 | 20mm | 14.1mm | 21.250             |
| KT-25 | 25mm | 17.7mm | 30.500             |
| KT-30 | 30mm | 21.2mm | 40.500             |
| KT-35 | 35mm | 24.8mm | 59.500             |
| KT-40 | 40mm | 28.3mm | 116.200            |
| KT-45 | 45mm | 31.8mm | 144.800            |
| KT-70 | 70mm | 49.5mm | 347.500            |

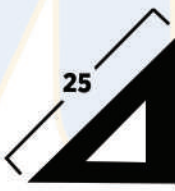
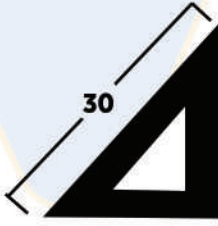

|        |   |   |   |  |   |
|--------|---|---|---|--|---|
|        |  |  |  |  |  |
|        | KT - 15   | KT - 20   | KT - 25   | KT - 30  | KT - 35   |
| CARTON | 200   | 200   | 100   | 100  | 100   |
| SIZE   | 15 mm   | 20 mm   | 25 mm   | 30 mm  | 35 mm   |

**HARGA DAPAT BERUBAH TANPA PEMBERITAHUAN  
TERLEBIH DAHULU DAN LOCO JAKARTA  
JAKARTA, 23 MARET 2016**

# PERFORMANCE DATA ROOFING SCREW

## SDS-BUGLE HEAD

Gypsum to Metal  
Used to attach gypsum to heavy gauge metal (20.14 ga.) walls and ceiling. Can be used with wood and plastic.

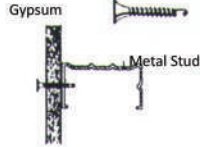

### SDS - BUGLE HEAD



SDS - BGE

SDS - BGE # 6 - 20 X 25 mm  
SDS - BGE # 6 - 20 X 32 mm  
SDS - BGE # 6 - 20 X 38 mm  
SDS - BGE # 6 - 20 X 41 mm

### SDS - COUNTERSUNK RIB HEAD



SDS - CRH

MAXIMUM  
WOOD  
THICKNESS

|                            |        |
|----------------------------|--------|
| SDS - CRH 8 X 18 X 28 mm   | 13 mm  |
| SDS - CRH 8 X 18 X 32 mm   | 17 mm  |
| SDS - CRH 8 X 18 X 37 mm   | 22 mm  |
| SDS - CRH 10 X 16 X 32 mm  | 15 mm  |
| SDS - CRH 10 X 16 X 37 mm  | 20 mm  |
| SDS - CRH 10 X 16 X 45 mm  | 28 mm  |
| SDS - CRH 10 X 16 X 60 mm  | 43 mm  |
| SDS - CRH 10 X 16 X 70 mm  | 53 mm  |
| SDS - CRH 10 X 16 X 85 mm  | 68 mm  |
| SDS - CRH 14 x 14 x 50 mm  | 33 mm  |
| SDS - CRH 14 x 14 x 70 mm  | 53 mm  |
| SDS - CRH 14 x 14 x 85 mm  | 68 mm  |
| SDS - CRH 14 x 14 x 95 mm  | 78 mm  |
| SDS - CRH 14 x 14 x 110 mm | 93 mm  |
| SDS - CRH 14 x 14 x 120 mm | 103 mm |

### NPH - BUGLE HEAD



NP - BFT

NPH - BFT # 6 - 18 X 25 mm  
NPH - BFT # 6 - 18 X 32 mm  
NPH - BFT # 6 - 18 X 38 mm  
NPH - BFT # 6 - 18 X 41 mm  
NPH - BFT # 6 - 18 X 50 mm

### NPH - BUGLE HEAD

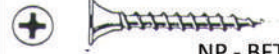

NP - BFT

NPH - BCT # 6 - 11 X 25 mm  
NPH - BCT # 6 - 11 X 32 mm  
NPH - BCT # 6 - 11 X 38 mm  
NPH - BCT # 6 - 11 X 41 mm  
NPH - BCT # 6 - 11 X 50 mm

### NPH-AN WASHER HEAD



NP - PWH

NPH - BCT # 6 - 11 X 25 mm  
NPH - BCT # 6 - 11 X 32 mm

## SDS - HEXAGON WASHER HEAD

Metal to Metal  
Valley Fixing  
Cladding

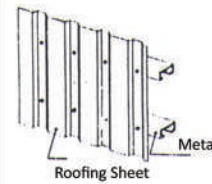

## SDS - TOPGRIP

Metal to Metal  
Crest Fixing  
Roofing

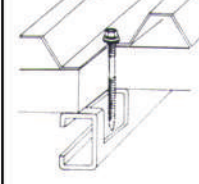

## SDS - HEXAGON WASHER FLANGE

Fibre Cement to Metal  
Fasten fibre cement corrugated sheets to purlin

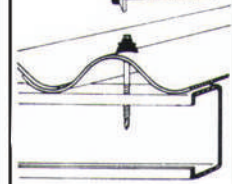

### SDS - HEXAGON WASHER HEAD



SDS - HWH

SDS - HWH # 10 - 16 X 13 mm  
SDS - HWH # 10 - 16 X 16 mm  
SDS - HWH # 10 - 16 X 20 mm  
SDS - HWH # 10 - 16 X 25 mm  
SDS - HWH # 10 - 16 X 35 mm  
SDS - HWH # 10 - 16 X 45 mm  
SDS - HWH # 12 - 14 X 20 mm  
SDS - HWH # 12 - 14 X 25 mm  
SDS - HWH # 12 - 14 X 35 mm  
SDS - HWH # 12 - 14 X 45 mm  
SDS - HWH # 12 - 14 X 55 mm  
SDS - HWH # 12 - 14 X 65 mm  
SDS - HWH # 14 - 14 X 20 mm  
SDS - HWH # 14 - 14 X 25 mm  
SDS - HWH # 14 - 14 X 35 mm  
SDS - HWH # 14 - 14 X 45 mm  
SDS - HWH # 14 - 14 X 55 mm  
SDS - HWH # 14 - 14 X 65 mm

### SDS - HEXAGON WASHER FLANGE



SDS - HWF

SDS - HWF # 12 - 24 X 20 mm  
SDS - HWF # 12 - 24 X 25 mm  
SDS - HWF # 12 - 24 X 35 mm  
SDS - HWF # 12 - 24 X 45 mm  
SDS - HWF # 12 - 24 X 55 mm  
SDS - HWF # 12 - 24 X 65 mm  
SDS - HWF # 12 - 24 X 75 mm  
SDS - HWF # 12 - 24 X 100 mm  
SDS - HWF # 12 - 24 X 125 mm  
SDS - HWF # 12 - 24 X 150 mm  
SDS - HWF # 12 - 24 X 175 mm  
SDS - HWF # 12 - 24 X 200 mm  
SDS - HWF # 14 - 20 X 65 mm  
SDS - HWF # 14 - 20 X 75 mm  
SDS - HWF # 14 - 20 X 100 mm  
SDS - HWF # 14 - 20 X 125 mm  
SDS - HWF # 14 - 20 X 150 mm  
SDS - HWF # 14 - 20 X 175 mm  
SDS - HWF # 14 - 20 X 200 mm

### NO.5-HEXAGON WASHER HEAD



NO.5 - HWH

NO.5 - HWH # 12 - 24 X 32 mm  
NO.5 - HWH # 12 - 24 X 50 mm  
NO.5 - HWH # 12 - 24 X 65 mm

### NP - HEXAGON WASHER HEAD



NP - HWH

NP - HWH # 10 - 12 X 19 mm  
NP - HWH # 10 - 12 X 22 mm  
NP - HWH # 10 - 12 X 25 mm

### TYPE 17 - HEXAGON WASHER HEAD



T17 - HWH

T17 - HWH # 10 - 12 X 25 mm  
T17 - HWH # 10 - 12 X 35 mm  
T17 - HWH # 10 - 12 X 50 mm

### SDS - TOPGRIP



SDS - HWFTG

SDS - HWFTG # 12 - 24/14 X 35 mm  
SDS - HWFTG # 12 - 24/14 X 45 mm  
SDS - HWFTG # 12 - 24/14 X 50 mm  
SDS - HWFTG # 12 - 24/14 X 65 mm  
SDS - HWFTG # 12 - 24/14 X 75 mm  
SDS - HWFTG # 12 - 24/14 X 100 mm  
SDS - HWFTG # 12 - 24/14 X 125 mm

### TYPE 17 - HEXAGON WASHER FLANGE



T17 - HWF

T17 - HWF # 12 - 11 X 50 mm  
T17 - HWF # 12 - 11 X 65 mm  
T17 - HWF # 12 - 11 X 75 mm  
T17 - HWF # 12 - 11 X 100 mm  
T17 - HWF # 14 - 10 X 50 mm  
T17 - HWF # 14 - 10 X 65 mm  
T17 - HWF # 14 - 10 X 75 mm  
T17 - HWF # 14 - 10 X 100 mm  
T17 - HWF # 14 - 10 X 125 mm

# PERFORMANCE DATA ROOFING SCREW

## SDS - HEXAGON WASHER HEAD

Metal to Metal

Valley Fixing  
Cladding

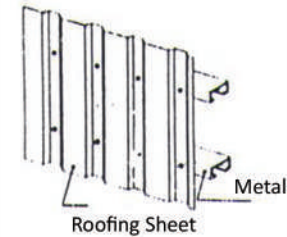

## SDS - TOPGRIP

Metal to Metal

Crest Fixing  
Roofing

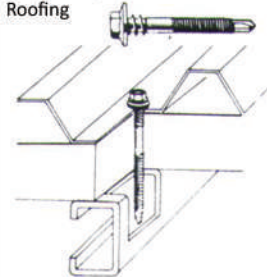

## SDS - HEXAGON WASHER FLANGE

Fibre Cement to Metal  
Fasten fibre cement corrugated sheets to purlin

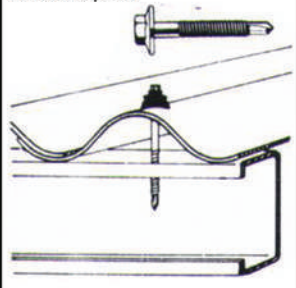

## SDS - HEXAGON WASHER HEAD



SDS - HWH

|                       |       |
|-----------------------|-------|
| SDS - HWH # 10 - 16 X | 13 mm |
| SDS - HWH # 10 - 16 X | 16 mm |
| SDS - HWH # 10 - 16 X | 20 mm |
| SDS - HWH # 10 - 16 X | 25 mm |
| SDS - HWH # 10 - 16 X | 35 mm |
| SDS - HWH # 10 - 16 X | 45 mm |
| SDS - HWH # 12 - 14 X | 20 mm |
| SDS - HWH # 12 - 14 X | 25 mm |
| SDS - HWH # 12 - 14 X | 35 mm |
| SDS - HWH # 12 - 14 X | 45 mm |
| SDS - HWH # 12 - 14 X | 55 mm |
| SDS - HWH # 12 - 14 X | 65 mm |
| SDS - HWH # 14 - 14 X | 20 mm |
| SDS - HWH # 14 - 14 X | 25 mm |
| SDS - HWH # 14 - 14 X | 35 mm |
| SDS - HWH # 14 - 14 X | 45 mm |
| SDS - HWH # 14 - 14 X | 55 mm |
| SDS - HWH # 14 - 14 X | 65 mm |

## NO.5-HEXAGON WASHER HEAD



NO.5 - HWH

|                        |       |
|------------------------|-------|
| NO.5 - HWH # 12 - 24 X | 32 mm |
| NO.5 - HWH # 12 - 24 X | 50 mm |
| NO.5 - HWH # 12 - 24 X | 65 mm |

## NP - HEXAGON WASHER HEAD



NP - HWH

|                      |       |
|----------------------|-------|
| NP - HWH # 10 - 12 X | 19 mm |
| NP - HWH # 10 - 12 X | 22 mm |
| NP - HWH # 10 - 12 X | 25 mm |

## TYPE 17 - HEXAGON WASHER HEAD



T17 - HWH

|                       |       |
|-----------------------|-------|
| T17 - HWH # 10 - 12 X | 25 mm |
| T17 - HWH # 10 - 12 X | 35 mm |
| T17 - HWH # 10 - 12 X | 50 mm |

## SDS - HEXAGON WASHER FLANGE

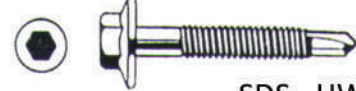

SDS - HWF

|                       |        |
|-----------------------|--------|
| SDS - HWH # 12 - 24 X | 20 mm  |
| SDS - HWH # 12 - 24 X | 25 mm  |
| SDS - HWH # 12 - 24 X | 35 mm  |
| SDS - HWH # 12 - 24 X | 45 mm  |
| SDS - HWH # 12 - 24 X | 55 mm  |
| SDS - HWH # 12 - 24 X | 65 mm  |
| SDS - HWH # 12 - 24 X | 75 mm  |
| SDS - HWH # 12 - 24 X | 100 mm |
| SDS - HWH # 12 - 24 X | 125 mm |
| SDS - HWH # 12 - 24 X | 150 mm |
| SDS - HWH # 12 - 24 X | 175 mm |
| SDS - HWH # 12 - 24 X | 200 mm |
| SDS - HWH # 14 - 20 X | 65 mm  |
| SDS - HWH # 14 - 20 X | 75 mm  |
| SDS - HWH # 14 - 20 X | 100 mm |
| SDS - HWH # 14 - 20 X | 125 mm |
| SDS - HWH # 14 - 20 X | 150 mm |
| SDS - HWH # 14 - 20 X | 175 mm |
| SDS - HWH # 14 - 20 X | 200 mm |

## SDS - TOPGRIP

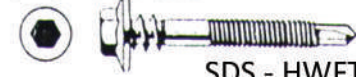

SDS - HWFTG

|                            |        |
|----------------------------|--------|
| SDS - HWFTG # 12 - 24/14 X | 35 mm  |
| SDS - HWFTG # 12 - 24/14 X | 45 mm  |
| SDS - HWFTG # 12 - 24/14 X | 50 mm  |
| SDS - HWFTG # 12 - 24/14 X | 65 mm  |
| SDS - HWFTG # 12 - 24/14 X | 75 mm  |
| SDS - HWFTG # 12 - 24/14 X | 100 mm |
| SDS - HWFTG # 12 - 24/14 X | 125 mm |

## TYPE 17 - HEXAGON WASHER FLANGE



T17 - HWF

|                       |        |
|-----------------------|--------|
| T17 - HWF # 12 - 11 X | 50 mm  |
| T17 - HWF # 12 - 11 X | 65 mm  |
| T17 - HWF # 12 - 11 X | 75 mm  |
| T17 - HWF # 12 - 11 X | 100 mm |
| T17 - HWF # 14 - 10 X | 50 mm  |
| T17 - HWF # 14 - 10 X | 65 mm  |
| T17 - HWF # 14 - 10 X | 75 mm  |
| T17 - HWF # 14 - 10 X | 100 mm |
| T17 - HWF # 14 - 10 X | 125 mm |

# PERFORMANCE DATA ROOFING SCREW

## TYPE 17-WAFER HEAD

Metal to Wood  
Wood to Wood



Fasten straps to purlin

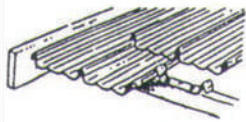

Wood Purlin

## SDS-COUNTERSUNK HEAD

Board to Metal



Head sink into board for flush finish

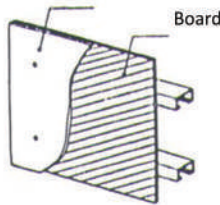

Board

## NO. 5 - WAFER HEAD



NO. 5 - WAF

NO. 5. WAF # 12 - 24 X 32 mm

NO. 5. WAF # 12 - 24 X 50 mm

NO. 5. WAF # 12 - 24 X 65 mm

## NO.5- HEXAGON WASHER HEAD



NO. 5 - HWH

NO. 5. HWH # 12 - 24 X 32 mm

NO. 5. HWH # 12 - 24 X 50 mm

NO. 5. HWH # 12 - 24 X 65 mm

## TYPE 17 - WAFER HEAD



T17 - WAF

T17-WAF # 10 - 12 X 25 mm

T17-WAF # 10 - 12 X 35 mm

T17-WAF # 10 - 12 X 25 mm

## SDS COUNTERSUNK HEAD



SDS - CSK

SDS CSK # 6 - 20 X 10 mm

SDS CSK # 6 - 20 X 13 mm

SDS CSK # 6 - 20 X 16 mm

SDS CSK # 6 - 20 X 20 mm

SDS CSK # 8 - 18 X 10 mm

SDS CSK # 8 - 18 X 13 mm

SDS CSK # 8 - 18 X 16 mm

SDS CSK # 8 - 18 X 20 mm

SDS CSK # 8 - 18 X 25 mm

SDS CSK # 10 - 16 X 16 mm

SDS CSK # 10 - 16 X 20 mm

SDS CSK # 10 - 16 X 25 mm

SDS CSK # 10 - 16 X 30 mm

SDS CSK # 10 - 16 X 35 mm

SDS CSK # 10 - 16 X 40 mm

SDS CSK # 10 - 16 X 45 mm

SDS CSK # 10 - 16 X 50 mm

## SDS - SELF EMBEDDING HEAD



SDS - SEH

SDS SEH # 8 - 18 X 20 mm

SDS SEH # 8 - 18 X 30 mm

SDS SEH # 10 - 16 X 35 mm

SDS SEH # 10 - 16 X 45 mm

SDS SEH # 10 - 16 X 55 mm

## TYPE 17 - COUNTERSUNK

JETTING SPIRAL



T17 - CJS

T17 - CJS M 4.0 - 14 X 38 mm

T17 - CJS M 4.0 - 14 X 45 mm

T17 - CJS M 4.0 - 14 X 50 mm

T17 - CJS M 4.0 - 14 X 65 mm

T17 - CJS M 4.0 - 14 X 75 mm

T17 - CJS M 5.0 - 11 X 50 mm

T17 - CJS M 5.0 - 11 X 65 mm

T17 - CJS M 5.0 - 11 X 75 mm

T17 - CJS M 5.0 - 11 X 90 mm

T17 - CJS M 5.0 - 11 X 100 mm

T17 - CJS M 5.0 - 11 X 115 mm

T17 - CJS M 5.0 - 11 X 125 mm

T17 - CJS M 5.0 - 11 X 140 mm

T17 - CJS M 5.0 - 11 X 155 mm

T17 - CJS M 6.0 - 10 X 90 mm

T17 - CJS M 6.0 - 10 X 100 mm

T17 - CJS M 6.0 - 10 X 115 mm

T17 - CJS M 6.0 - 10 X 125 mm

T17 - CJS M 6.0 - 10 X 140 mm

T17 - CJS M 6.0 - 10 X 155 mm

## S-DD special dywall screws, framing

Application

Fastening metal studs together, sheet steel from 0.7 mm to studs up to max. 2.0 mm thick

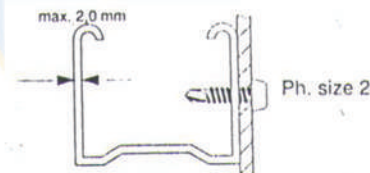

Type of screw

S - DD 02  
zinc-plated



## S-DD special dywall screws, lathing

Application

Fastening wire lathing, light construction panels and metal connection structures to metal studs from 0.7 mm up to max. 2,5 mm thick

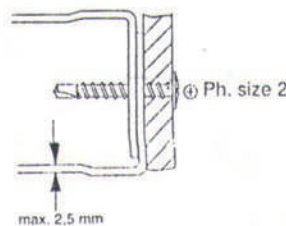

Type of screw

S - DD 03  
zinc-plated



# SELF DRILLING SCREW

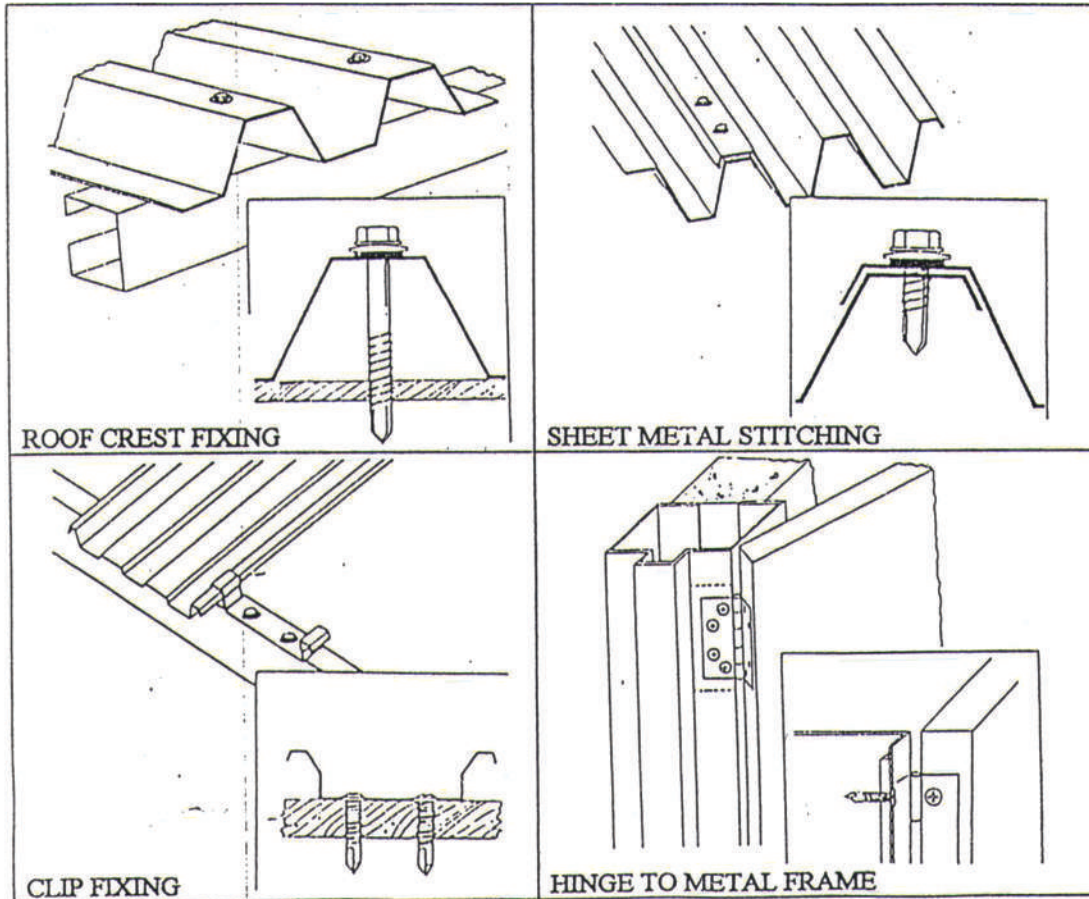

## PERFORMANCE SPECIFICATIONS:

| SCREW SIZE | THREADS PER INCH | DRILLING SPECIFICATIONS |                     |                           | Ultimate Strength |                 |
|------------|------------------|-------------------------|---------------------|---------------------------|-------------------|-----------------|
|            |                  | Max. Mat Thickness (mm) | Axial Load (N) Max. | Typical Drilling Time/Sec | Min Tension (KN)  | Min Torque (Nm) |
| NO. 6      | 20               | 2,5                     | 178                 | 3                         | 5,34              | 2,9             |
| NO. 8      | 18               | 3,2                     | 178                 | 4                         | 8,46              | 5,6             |
| NO. 10     | 24               | 4,5                     | 267                 | 5                         | 10,46             | 7,3             |
| NO. 12     | 24               | 5,4                     | 267                 | 7                         | 14,46             | 11,3            |
| NO. 14     | 24               | 6,3                     | 267                 | 8                         | 10,02             | 19              |

Drilling times determined in unhardened low carbon steel plates

## DRILKWICK SCREW SPECIFICATION

| SCREW SIZE | MEAN THREAD Dia. MM | T.P.I | LENGTH AVAILABLE (MM)           |
|------------|---------------------|-------|---------------------------------|
| NO. 6      | 3,43                | 20    | On Application                  |
| NO. 8      | 4,10                | 18    | 12, 16                          |
| NO. 10     | 4,74                | 24    | 16, 20, 40, 50                  |
| NO. 12     | 5,40                | 24    | 20, 25, 35, 45, 55, 65, 75, 100 |
| NO. 14     | 6,25                | 24    | On Application                  |



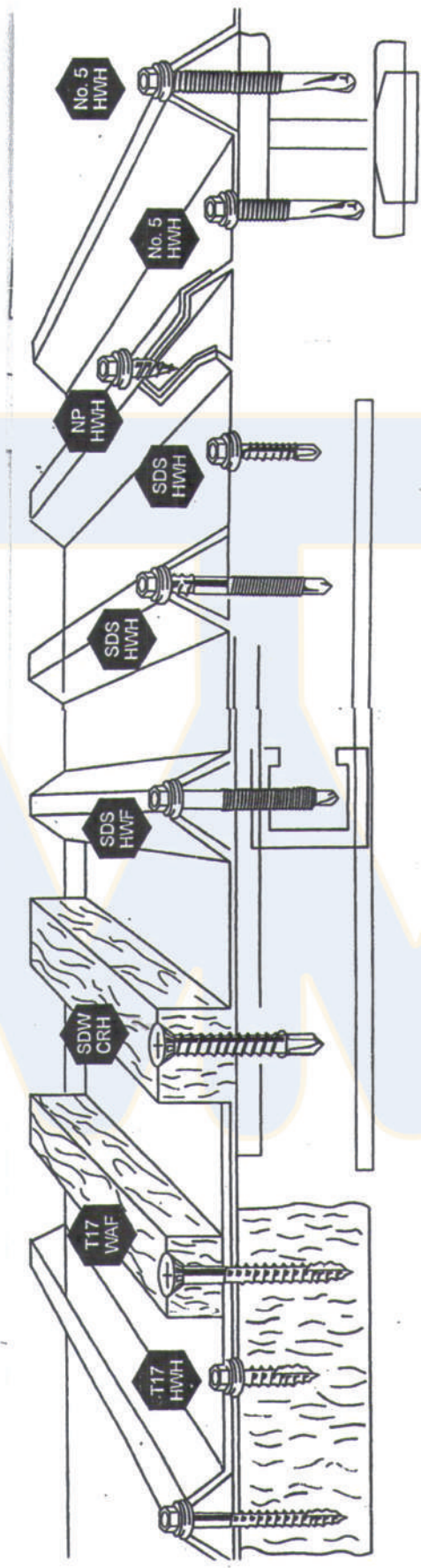

# PERFORMANCE DATA

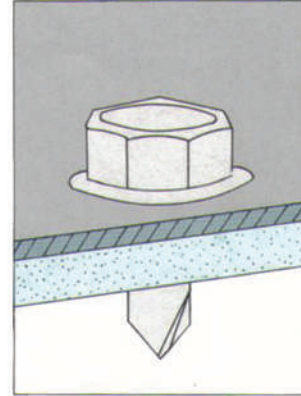
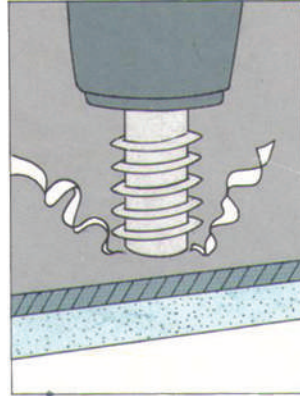
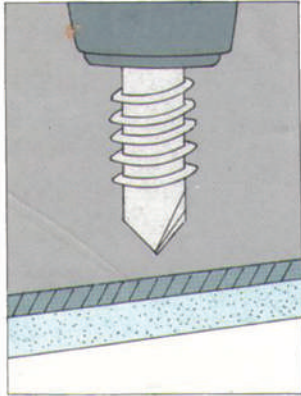

| SCREW SIZE   | THREADS PER INCH | DRILLING PERFORMANCE SPECIFICATIONS |                  |                             | SUITABLE FASTENING SUBJECT'S THICKNESS (M/M) |           | ULTIMATE STRENGTH |                    |
|--------------|------------------|-------------------------------------|------------------|-----------------------------|--|-----------|-------------------|--------------------|
|              |                  | TEST LOADING (KGS)                  | TEST SHEET (M/M) | TYPICAL DRILLING TIME (SEC) | POINT #2                                     | POINT #3  | MIN TENSION LBS   | MIN TORQUE (KG-CM) |
| NO. 4        | 24               | 15.9                                | 1.57 - 1.73      | 2,0                         | 0.9 - 2.0                                    | -         | 750               | 14                 |
| NO. 6        | 20               | 15.9                                | 1.57 - 1.73      | 2,5                         | 0.9 - 2.2                                    | 2.3 - 3.2 | 1125              | 25                 |
| NO. 8        | 18               | 15.9                                | 1.57 - 1.73      | 3,0                         | 0.9 - 2.5                                    | 2.5 - 3.6 | 1575              | 42                 |
| NO. 10       | 16               | 18.1                                | 1.57 - 1.73      | 3,5                         | 0.9 - 2.8                                    | 2.8 - 4.4 | 2100              | 61                 |
| NO. 12       | 14               | 22.7                                | 1.57 - 1.73      | 4,0                         | 0.9 - 3.6                                    | 2.8 - 5.7 | 2800              | 92                 |
| NO. 14 (1/2) | 14               | 22.7                                | 1.57 - 1.73      | 5,0                         | 0.9 - 4.5                                    | 2.8 - 6.3 | 3850              | 150                |

ABOVE DRILLING TIMES ARE TESTED ON FASTENING UNHARDENED, LOW CARBON STEEL PLATES  
SCREW LENGTH: MAX. 115 M/M

DRILLING TOOLS : A POWER SCREW DRIVER WITH DRIVING SPEED BETWEEN 2000 TO 2500 RPM IS RECOMMENDED FOR ALL SIZES EXCEPT #12 AND 1/4 (ASA). USE 1800 TO 2000 RPM. SPEED DRIVERS ON SIZES #12 AND #14(1/4)

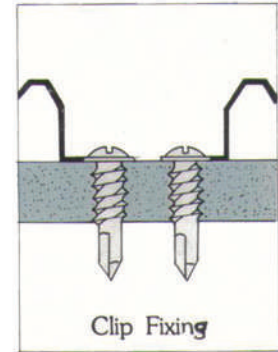
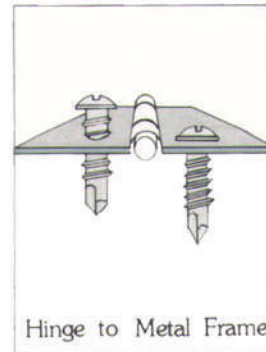
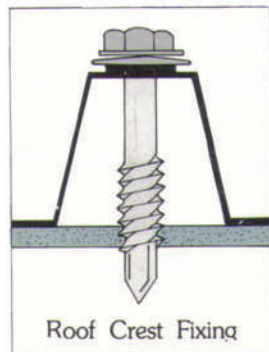
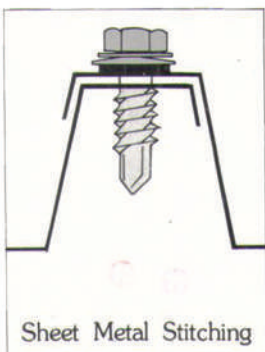

# C - PRESSING

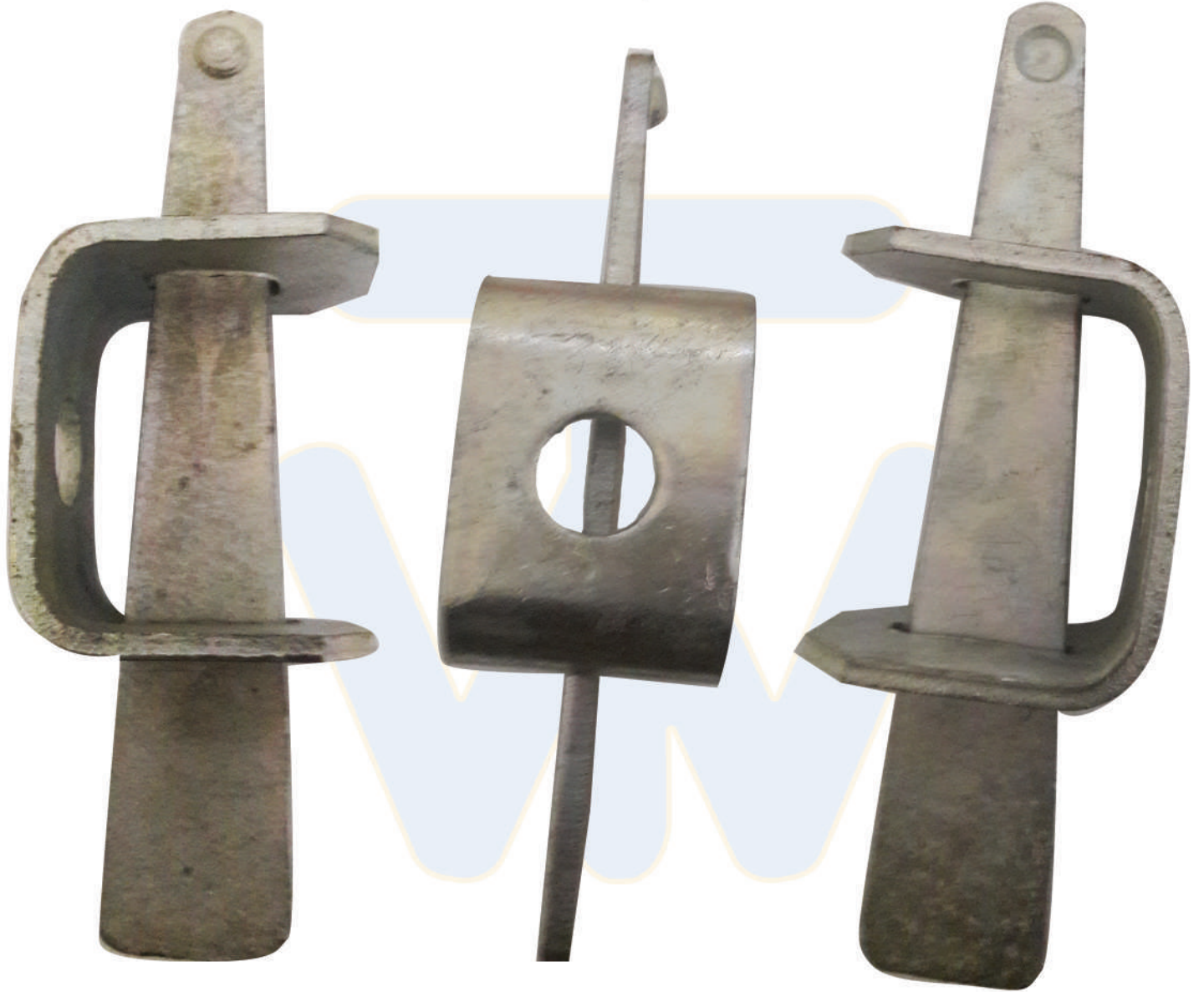

# CLAMP FORGET



# HEAVY DUTY COUPLER



# SLEEVE PIPE COUPLER

